

Serie GR/F Plug Check Valve Solid plug



Keep for future use!

This operating manual must be strictly observed before transport, installation, operation and maintenance

Subject to change without notice.

Reproduction is generally permitted with indication of the source.

© Richter Chemie-Technik GmbH

9550-075-en Revision 10 Edition 10/2011

List of Contents

List of Contents	2	6 Installation	8
Relevant documents	2	6.1 Flange caps and gaskets.....	8
1 Technical data	2	6.2 Direction of flow and installation position....	8
1.1 Name plate, CE and body markings.....	3	6.3 Grounding.....	8
1.2 Tightening torques.....	3	6.4 Test pressure.....	8
1.3 Screw-in tool for seat.....	4	7 Operation	8
1.4 Pressure/temperature diagram.....	4	7.1 Initial commissioning.....	8
2 Notes on safety	5	7.2 Improper operation and their consequences	8
2.1 Intended use.....	5	7.3 Shutdown.....	8
2.2 For the customer / operator.....	5	8 Malfunctions	9
2.3 Improper operation.....	5	9 Maintenance	9
3 Safety notes for applications in potentially explosive areas based on the Directive 94/9/ EC (ATEX)	6	9.1 Demontage.....	9
3.1 Intended use.....	6	9.1.1 Replacing plug.....	9
4 Safety note for valves, certified to Clean Air Act (TA Luft)	7	9.1.2 Replacing seat.....	9
5 Transport, storage and disposal	7	9.2 Montage.....	9
5.1 Storage.....	7	10 Drawing	10
5.2 Return consignments.....	7	10.1 Legend.....	10
5.3 Disposal.....	7	10.2 Sectional drawing.....	10
		10.3 Dimensional drawing.....	11

Relevant documents

- ◆ Declaration of conformity acc. to the EC Pressure Equipment Directive 97/23/EC
- ◆ Manufacturer's Declaration German Clean Air Act (TA-Luft)
- ◆ Form for Safety Information Concerning the Contamination QM 0912-16-2001_en

1 Technical data

Manufacturer:

Richter Chemie-Technik GmbH
 Otto-Schott-Str. 2
 D-47906 Kempen
 Telephone : +49 (0) 2152 146-0
 Fax: +49 (0) 2152 146-190
 E-Mail: richter-info@richter-ct.com
 Internet: <http://www.richter-ct.com>

Designation :

Plug check valve, series GR/F with solid plug
 Certified to Clean Air Act (TA Luft)
 Strength and tightness (P10, P11) of the pressure-bearing body tested to DIN EN 12266-1.

Gas-tight (P12) in the seat to DIN EN 12266-1, leak rate A.

Face to face alternatively:

- EN 558-1 basic series 1, ISO 5752 series 1 with flanges DIN EN 1092-2, type B (ISO 7005-2 Type B) PN 16 or flanges drilled to ASME B16.5 Class 150
- ANSI/ISA-75.08.01, Class 150 with flanges ASME B16.5 Class 150, raised face

Materials :

Body material: Ductile cast iron EN-JS 1049 / ASTM A395

Lining material: PFA/F
 on request : conductive lining .../F-L

Temperature range :

See pressure-temperature diagram in [Section 1.4](#).

Operating pressure: from vacuum to max. 16 bar

See pressure-temperature diagram in [Section 1.4](#).

Sizes :

DN 15, 20, 25, 40, 50, 65, 80, 100

ASME 1/2", 3/4", 1", 1 1/2", 2", 3", 4"

Weight:

Nom. size	15	20	25	40	50	65	80	100
ASME	1/2"	3/4"	1"	1 1/2"	2"	---	3"	4"
ca. kg	6	6	11	17	19	20	39	44

Installation position:

Installation position horizontal. Make sure that the cover is on top.

A direction arrow on the shell indicates the direction of flow. See [Section 6.2](#).

Dimensions and individual parts:

See sectional drawing in [Section 10](#)

Wear parts: Plug, seat

1.1 Name plate, CE and body markings

The stainless steel name plate is undetachably riveted to the body.

If the operator attaches his identification, it must be ensured that the valve matches the application in question.

Example of name plate with CE marking

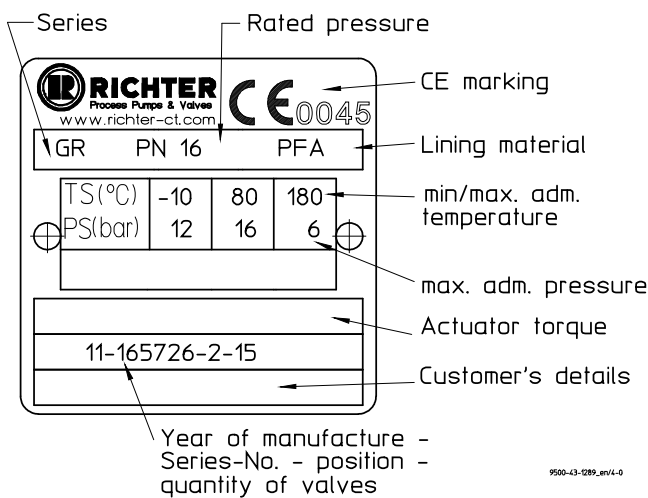

No CE marking is permissible for the sizes 15, 20 and 25; the name plate therefore has no CE marking.

Body identification:

The following are visible on the body according to DIN EN 19 and AD 2000 A4:

- ◆ Nominal size
- ◆ Rated pressure
- ◆ Body material
- ◆ Manufacturer's identification
- ◆ Melt number/Foundry identification
- ◆ Cast date
- ◆ Arrow for direction of flow

1.2 Tightening torques

All screws greased, tighten in diametrically opposite sequence!

The tightening torques for pipe screws and body screws mentioned must not be exceeded. For an exception, see [Section 8](#), Flange connection valve / pipe is leaking.

The following tightening torques are recommended.

Pipe screws, flanges to ISO/DIN

Flange nom. size	Screws		Tightening torque	
	[mm]	[inch]	[Nm]	[in-lbs]
15	1/2"	4 x M12	6	55
20	3/4"	4 x M12	8	70
25	1	4 x M12	10	90
40	1 1/2"	4 x M16	20	175
50	2	4 x M16	26	230
65	--	4 x M16	40	355
80	3	8 x M16	25	220
100	4	8 x M16	35	310

Pipe screws, flanges to ASME Class 150 or flanges ISO/DIN drilled to ASME Class 150

Flange nom. size	Screws		Tightening torque	
	[mm]	[inch]	[mm]	[inch]
15	1/2"	4 x 1/2"	5	45
20	3/4"	4 x 1/2"	6	55
25	1"	4 x 1/2"	8	70
40	1 1/2"	4 x 5/8"	15	135
50	2"	4 x 5/8"	25	220
65	---	4 x 5/8"	30	265
80	3"	4 x 5/8"	45	400
100	4"	8 x 5/8"	35	310

Cover screws

Flange nom. size		Screws	Tightening torque	
[mm]	[inch]		[ISO/DIN]	[Nm]
15	1/2"	4 x M10	30	266
20	3/4"	4 x M10	30	266
25	1	4 x M12	50	442
40	1 1/2	4 x M12	50	442
50	2	4 x M12	50	442
65	--	4 x M12	50	442
80	3	8 x M12	50	442
100	4	8 x M12	50	442

1.3 Screw-in tool for seat

Nom. diameter		Article No.
[mm]	[inch]	
15, 20	1/2", 3/4"	9568-96-1011
25	1"	9568-96-1001
40	1 1/2"	9568-96-1002
50, 65	2"	9568-96-1003
80	3"	9568-96-1004
100	4"	9568-96-1005

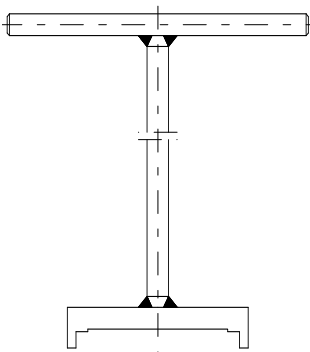
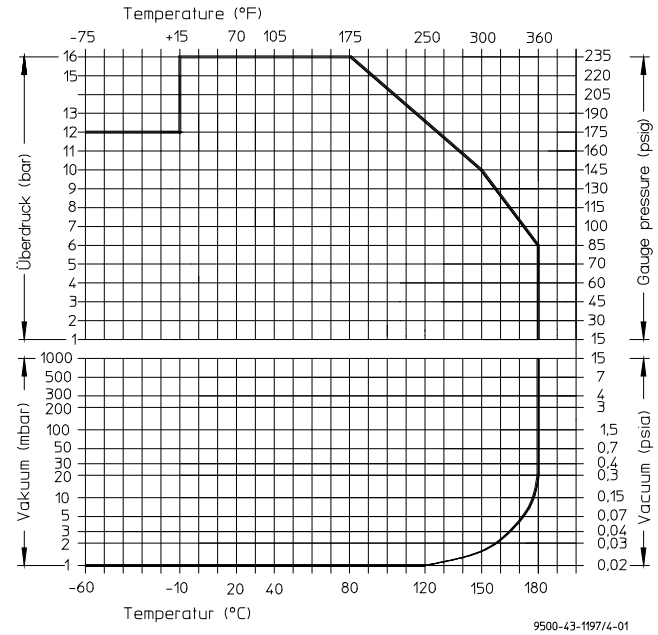

Fig. 1

1.4 Pressure/temperature diagram

According to AD 2000



According to ASME B 16.42

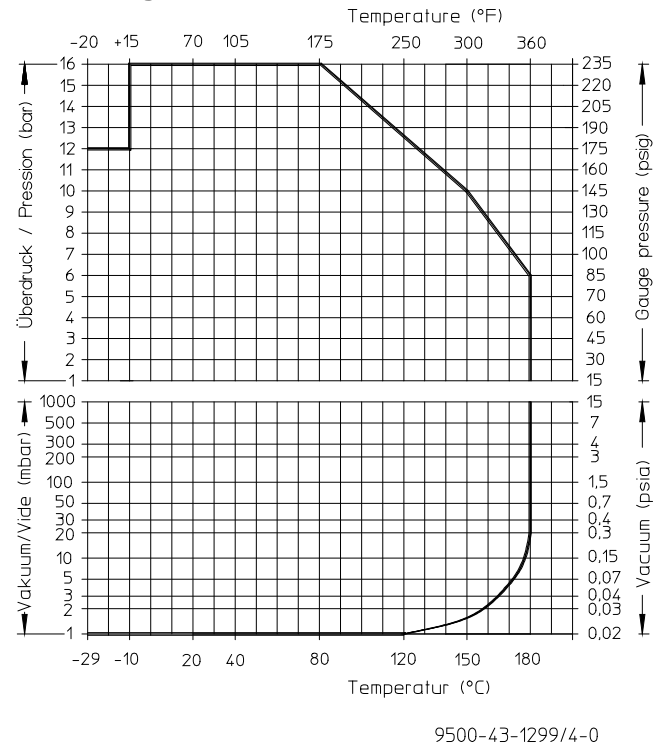

When used in the area of application of ASME, the low temperature of ASTM A395 is limited to -20°F (-29°C).



When used in the minus temperature range, the regulations applicable in the country in question must be observed.

2 Notes on safety

This operating manual contains fundamental information which is to be observed during installation, operation and maintenance. It must therefore be read before installation and commissioning.

For valves which are used in potentially explosive areas, see **Section 3**.

Installation and operation are to be performed by qualified staff.

The area of responsibility, authority and supervision of the staff must be regulated by the customer.



General hazard symbol!

People may be put at risk.



Safety symbol! The ball valve and its function may be put at risk if this safety symbol is not observed.

It is imperative to observe warnings and signs attached directly to the ball valve and they are to be kept fully legible.

Non-observance of the notes on safety may result in the loss of any and all claims for damages.

For example, non-observance may involve the following hazards:

- ◆ Failure of important functions of the valve/plant.
- ◆ Risk to people from electric, mechanical and chemical effects.
- ◆ Risk to the environment through leaks of hazardous substances.

2.1 Intended use

Richter check valves of the series GR/F are pressure-maintaining items of equipment in accordance with the German Pressure Equipment Directive (DGRL) for the passage of fluids in the direction of the flow arrow provided on the body and for blocking the passage in the opposite direction.

The GR/F is intended for horizontal installation.

The valves are suitable for vapours, gases and fluids of group 1 in acc. with the Pressure Equipment Directive.

The operator must carefully check in the event of operating data other than those provided whether the designs of the strainer, accessories and materials are suitable for the new application (consultation with the manufacturer).

2 For the customer / operator

When using the valve, it must be ensured that

- ◆ hot or cold valve parts are protected by the customer against being touched
- ◆ the valve has been properly installed in the pipe system
- ◆ the usual flow rates are not exceeded in continuous operation.

This is not the manufacturer's responsibility.

Loads caused by earthquakes were not allowed for in the design.

Fire protection to DIN EN ISO 10497 is not possible (plastic lining and plastic components).

2.3 Improper operation

The operational reliability of the valve supplied is only guaranteed if it is used properly in accordance with **Section 2.1** of this operating manual.



The operation limits specified on the identification plate and in the pressure-temperature diagram must under no circumstances be exceeded.

3 Safety notes for applications in potentially explosive areas based on the Directive 94/9/ EC (ATEX)

The valves are intended for use in a potentially explosive area and are therefore subject to the conformity assessment procedure of the directive 94/9/EC (ATEX).

As part of this conformity assessment, an ignition hazard analysis to EN 13463-1 to satisfy the fundamental safety and health requirements was conducted with the following result:

- ◆ **The valves do not have any ignition source of their own.**
- ◆ **The valves are not covered by the scope of application of the ATEX directive and therefore do not need to be identified accordingly.**
- ◆ **The valves may be used in a potentially explosive area.**

It is imperative to observe the individual points of intended use for application in a potentially explosive area.

3.1 Intended use

Improper operation, even for brief periods, may result in serious damage to the valve.

In connection with explosion protection, potential sources of ignition (overheating, electrostatic and induced charges, mechanical and electric sparks) may result from these improper operation; their occurrence can only be prevented by adhering to the intended use.

Furthermore, reference is made in this connection to the Directive 95/C332/06 (ATEX 118a) which contains the minimum regulations for improving the occupational health and safety of the workers who may be at risk from an explosive atmosphere.

A difference is made between two cases for the use of chargeable liquids (conductivity $<10^{-8}$ S/m):

1. Chargeable liquid and non-conductive lining

Charges can occur on the lining surface. As a result, this can produce discharges inside the valve. However, these discharges cannot cause ignitions if the valve is completely filled with medium.

If the valve is not completely filled with medium, e.g. during evacuation and filling, the formation of an explosive atmosphere must be prevented, e.g. by superimposing a layer of nitrogen. It is recommended to wait 1 hour before removing the valve from the plant in order to permit the elimination of static peak charges.

This means that, to safely prevent ignitions, the valve must be completely filled with medium at all times or else a potentially explosive atmosphere must be excluded by superimposing a layer of inert gas.

2. Chargeable liquid and conductive lining

No hazardous charges can occur as charges are discharged direct via the lining and shell (surface resistance $<10^9$ Ohm, leakage resistance $<10^6$ Ohm).

Static discharges of non-conductive linings are only produced through the interaction with a non-conductive medium and are therefore the responsibility of the plant operator.

Static discharges are not sources of ignition which stem from the valves themselves!

- The temperature of the medium must not exceed the temperature of the corresponding temperature class or the maximum admissible medium temperature as per the operating manual.
- If the valve is heated (e.g. heating jacket), it must be ensured that the temperature classes prescribed in the Annex are observed.
- To achieve safe and reliable operation, it must be ensured in inspections at regular intervals that the valve is properly serviced and kept in technically perfect order.
- Increased wear to the valve can be expected with the conveyance of liquids containing abrasive constituents. The inspection intervals are to be reduced compared with the usual times.
- Actuators and electric peripherals, such as temperature, pressure and flow sensors etc., must comply with the valid safety requirements and explosion protection provisions.
- The valve must be grounded.
This can be achieved in the simplest way via the pipe screws using tooth lock washers. Otherwise grounding must be ensured by other action, e.g. cable bridges.
- Plastic-lined valves must not be operated with carbon disulphide.

4 Safety note for valves, certified to Clean Air Act (TA Luft)

On request, this valve can be supplied compliant with the German Clean Air Code.

Certificate / Manufacturer Declaration Validity is dependent on the operating instructions being read and observed.

In particular, servicing must be conducted at regular intervals, and the bolted connections relevant for tightness must be inspected and retightened if necessary.

5 Transport, storage and disposal



It is imperative, for all transport work, to observe generally accepted engineering practice and the accident prevention regulations.



The valve is supplied with flange caps. Do not remove them until just before installation. They protect the plastic surfaces against dirt and mechanical damage.

Handle the goods being transported with care. During transport the valve must be protected against impacts and collisions.

Directly after receipt of the goods, the consignment must be checked for completeness and any in-transit damage.

Do not damage paint protection.

5.1 Storage

If the valve is not installed immediately after delivery, it must be put into proper storage.

It should be stored in a dry, vibration-free and well-ventilated room at as constant a temperature as possible.

Elastomers are to be protected against UV light.

In general, a storage period of 10 years should not be exceeded.

5.2 Return consignments

Valves which have conveyed aggressive or toxic media must be well rinsed and cleaned before being returned to the manufacturer's works.

It is **imperative** to enclose a **safety information sheet / general safety certificate** on the field of application with the return consignment.

Pre-printed forms are enclosed with the installation and operating manual.

Safety precautions and decontamination measures are to be mentioned.

5.3 Disposal

Parts of the valve may be contaminated with medium which is detrimental to health and the environment and therefore cleaning is not sufficient.



Risk of personal injury or damage to the environment due to the medium!

- ◆ Wear protective clothing when work is performed on the valve.
- ◆ Prior to the disposal of the valve:
 - Collect any medium, etc. which has escaped and dispose of it in accordance with the local regulations.
 - Neutralise any medium residues in the valve.
- ◆ Separate valve materials (plastics, metals, etc.) and dispose of them in accordance with the local regulations.

6 Installation

- ◆ Examine valve for in-transit damage, damaged check valves must not be installed.
- ◆ Before installation the valve and the connecting pipe must be carefully cleaned to remove any dirt, especially hard foreign matter.
- ◆ During installation, pay attention to the correct tightening torque, aligned pipes and tension-free assembly.

6.1 Flange caps and gaskets

Leave protective caps on the flanges until just prior to installation.

Where there is a particularly high risk of damage to the plastic sealing surfaces, e.g. if the mating flanges are made of metal or enamel, PTFE-lined gaskets with a metal inlay should be used. These gaskets are available as special accessories in the Richter range.

6.2 Direction of flow and installation position

The direction of flow must be observed when installing the valve. It is indicated by a direction arrow on the valve body.

The closing operation is already initiated by the gravity of the closing element when the flow rate decreases.

Plug check valves are particularly streamlined. The solid plug seals against a falling or back-flowing liquid level.

Only a horizontal installation position is possible for the check valve GR/F. Make sure that the cover is on top.

6.3 Grounding

The valve must be grounded. The simplest solution is to use tooth lock washers which are placed under one pipe bolt of each flange.

At the customer's request a setscrew M6 with a hex. nut and washer will be provided at each flange as an additional grounding connection.

Otherwise grounding must be ensured by different measures e.g. a cable link.

6.4 Test pressure

The test pressure PT of a valve must not exceed the value of $1.5 \times PS(PN)$ as per the identification of the valve.

7 Operation

7.1 Initial commissioning

Normally, the valves have been tested for leaks with air or water. Prior to initial operation check cover screws. For torques see [Section 1.2](#).



Unless otherwise agreed, there could be residual amounts of water in the flow section of the ball valve; this could result in a possible reaction with the medium.

To prevent leaks, all connection screws should be retightened after the initial loading of the valve with operating pressure and operating temperature. For torques, see [Section 1.2](#).

7.2 Improper operation and their consequences

- ◆ Crystallisation must be prevented, e.g. by heating. In the extreme case a blockage may occur.
- ◆ Increased wear occurs in operation with solids contents.

- ◆ Increased wear occurs in operation under cavitation.
- ◆ Non-observance of the pressure-temperature diagram can lead to damage.

7.3 Shutdown

- ◆ The local regulations are to be observed when dismantling the valve.



Prior to undoing the flange connection ensure, that the plant is depressurised and emptied.

- ◆ Prior to starting any repair work, the valve is to be thoroughly cleaned. Even if the valve has been properly emptied and rinsed, residual medium may still be found in the valve,
- ◆ After dismantling, immediately protect the valve flanges against mechanical damage with flange caps. See also [Section 6.1](#).

8 Malfunctions

◆ Flange connection valve/pipe is leaking

Retighten the flange screws to a tightening torque according to Section 1.2. If this does not remedy the leak, the recommended torques may be exceeded by 10%.

If this also fails to stop the leak, dismantle and inspect the valve.

◆ Flange connection main body/body end piece is leaking

Retighten body screws. See paragraph "Flange connection ball valve/pipe is leaking".

◆ Valve does not close

Are there solids between the sealing surface and the ball?

Is the sealing surface damaged?

Is the ball damaged?

9 Maintenance

◆ All repair work is to be performed by qualified personnel using the appropriate tools. Generally recognised practice in mechanical engineering is to be observed.

◆ For the arrangement, designation and item numbers of all parts of the valve, see **Section 10**.

◆ Spare parts are to be ordered with all the details in acc. with the valve identification.

◆ **Only original spare parts may be installed.**

◆ To prevent leaks, a regular check of the connection screws should be made in line with the operating requirements.

For torques see **Section 1.2**.

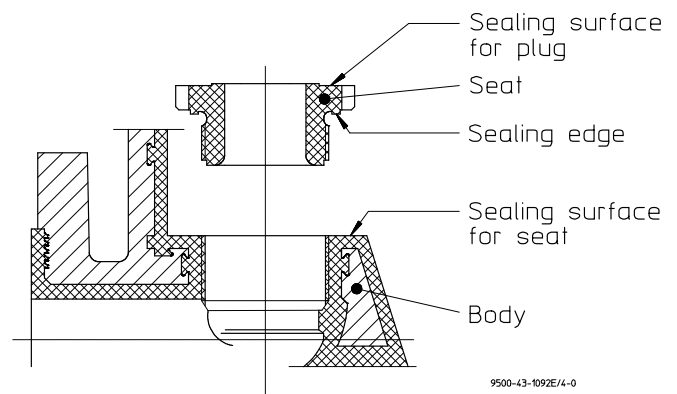

9.1 Demontage

9.1.1 Replacing plug

- Remove cover screws **901/1, 936/1** (with DN 100 **902/2, 936/1, 920/3**).
- Pull guide **801** with shank **808** and valve plug **204** out of the body **100**.
- DN 25-100
Pull round cord **522** with pliers out of the valve plug **204**.
- Replace valve plug **204**.
- Check to see whether the seat **205** is still OK:
- If not: **Replace**. See **Section 9.1.2**.

9.1.2 Replacing seat

A screw-in tool is required for the assembly and dismantling of the seat **205**. The article numbers for the individual nominal sizes are listed in **Section 1.3**.

The new seat must be carefully protected prior to assembly. The sealing edge and the sealing surface for the plug must not be damaged.

- Remove the upper part of the valve as described in **Section 9.1.1**.
- Screw the seat **205** out of the body with the Richter screw-in tool. **Right-hand thread**.
- Carefully clean the sealing surface in the body **100** and check for damage.
- If there is any damage, you can try to rework the sealing surface.
- Screw the new seat **205** without lubricant into the body using the Richter screw-in tool.

9.2 Montage

- Assembly is performed in reverse sequence.
- Prior to assembly all parts must be cleaned and the plastic-lined parts checked for damage.
- Bolt body **100** and cover **106** together. Tighten the screws in diametrically opposing sequence to a torque indicated in **Section 1.2**.

10 Drawing

10.1 Legend

100	body	801	guide
106	cover	808	shank
204	plug	901/1	hex. screw
205	seat	902/1	stud screw (DN 100)
244	plug with shaft	920/1	hex. Nut
522	round cord	936/1	toothed lock washer

10.2 Sectional drawing

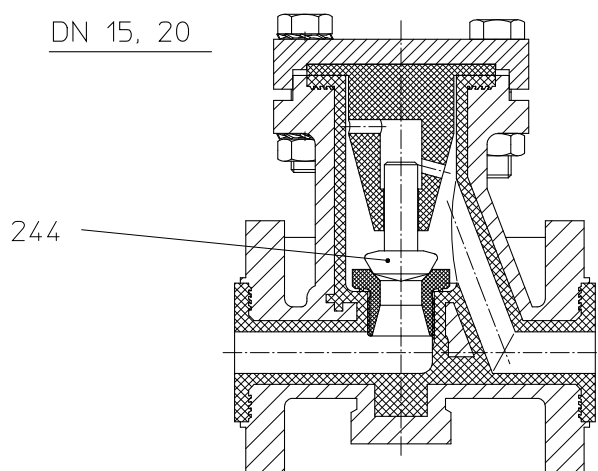
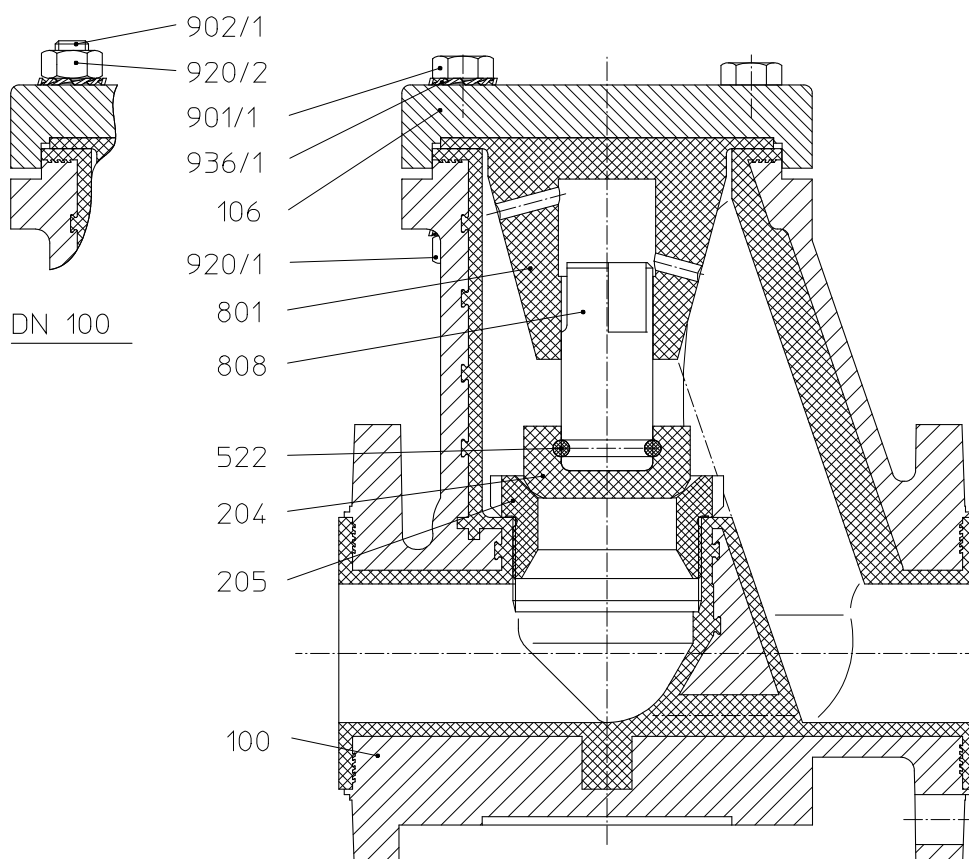

10.3 Dimensional drawing

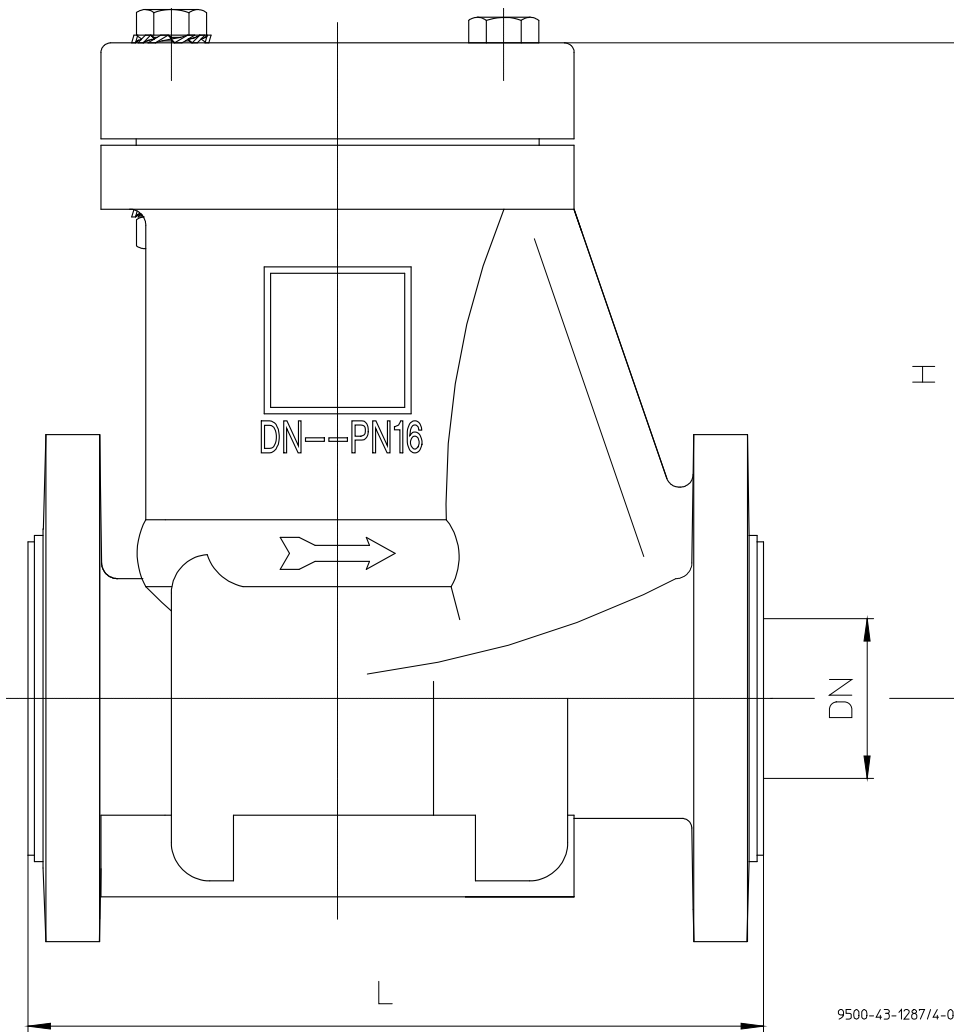

Face to face with flanges to ISO/DIN, PN 16 or flanges drilled to ASME B16.5 Class 150

DN	15/20	25	40	50	65	80	100
L	130	160	200	230	290	310	350
H	112	156	197	205	205	313	327

dimensions in mm

Face to face to ANSI/ISA 78.08.01, class 150, flanges to ASME B16.5 Class 150

DN	1/2" / 3/4"	1"	1 1/2"	2"	2 1/2"	3"	4"
L	130 *	185	222	254	--	298	350 *
H	112	156	197	205	---	313	327

dimensions in mm

* dimensions not acc. to ANSI/ISA

CE Konformitätserklärung nach EN ISO//IEC 17050
Declaration of Conformity according to EN ISO//IEC 17050

Produkt <i>Product</i>	Kunststoffausgekleidete Rückschlagventile <i>Plastic lined check valves</i>
Bauart <i>Design</i>	Kugelrückschlagventil, Kegelrückschlagventil, Rückschlagventil mit integriertem Schauglas <i>Ball check valve, plug check valve, check valve with integrated sight glass</i>
Baureihe <i>Series</i>	BC, BCV, CV, CVV, GR, RV, SR, SR-B, SRV, SRV-B, SRZ-V
Nennweite <i>Size</i>	DN 15 bis DN 200, ½" bis 6" <i>DN 15 to DN 200, ½" to 6"</i>
Seriennummer <i>Series number</i>	ab/from 29.12.2009
EU-Richtlinie <i>EU-Directive</i>	97/23/EG Druckgeräterichtlinie <i>97/23/EC Pressure Equipment Directive</i>
Angewandte Technische Spezifikation <i>Applied Technical Specification</i>	DIN EN ISO 12100-2 AD 2000
Überwachungsverfahren <i>Surveillance Procedure</i>	97/23/EG Zertifizierungsstelle für Druckgeräte der TÜV Nord Systems GmbH & Co. KG Notified Body 0045
Konformitätsbewertungsverfahren 97/23/EG <i>Conformity assessment procedure 97/23/EC</i>	Modul H
Kennzeichnung <i>Marking</i>	97/23/EG ¹⁾ ≥ DN 32, ≥ 1" 97/23/EC ¹⁾ ≥ DN 32, ≥ 1" CE0045

Das Unternehmen Richter Chemie-Technik GmbH bescheinigt hiermit, dass die o.a. Baureihen die grundsätzlichen Anforderungen der aufgeführten Richtlinien und Normen erfüllt.
Richter Chemie-Technik GmbH confirms that the basic requirements of the above specified directives and standards have been fulfilled.

¹⁾ Für nicht aufgeführte Nennweiten ist eine Kennzeichnung nicht zulässig.
For sizes not listed a marking is not permissible.

Kempen, 14.01.2011



G. Kleining
Leiter Forschung & Entwicklung
Manager Research & Development



A. Linges
Leiter Qualitätsmanagement
Quality Manager

Herstellereklärung / *Manufacturer's Declaration*

TA-Luft / *German Clean Air Act (TA-Luft)*

Richter Rückschlagventil / *Richter Check Valve*

Hiermit erklären wir, dass die Rückschlagventile der Baureihen
Hereby we declare, that the Check Valves of the series

CV, BC, SR, GR, RV, PRS

die Anforderung bezüglich der Gleichwertigkeit gemäß Ziffer 5.2.6.4 der Technischen Anleitung-Luft (TA-Luft vom 01.10.2002 / VDI 2440 Ziffer 3.3.1.3) erfüllen.

Grundlage sind die "Prüfgrundsätze für den Eignungsnachweis von Spindelabdichtungen in Armaturen als gleichwertig nach TA-Luft" des TÜV Süddeutschland Bau und Betrieb GmbH vom 22.09.1992.

Die Herstellereklärung beinhaltet den Eignungsnachweis einer inneren Flanschverbindung gemäß VDI 2440 hinsichtlich Dichtheit bzw. der Einhaltung der spezifischen Leckagerate nach TA-Luft $\lambda \leq 10^{-4} \frac{\text{mbar} \cdot \text{l}}{\text{s} \cdot \text{m}}$ und einer erweiterten Prüfung unter Betriebsbedingungen.

Voraussetzung für die Gültigkeit der Herstellereklärung ist das Beachten und Einhalten der Betriebsanleitung. Insbesondere sind regelmäßige Wartungsintervalle durchzuführen und die dichtheitsrelevanten Schraubverbindungen zu überprüfen und, wenn notwendig, nachzuziehen.

meets the requirement relating to the equivalence according to Section 5.2.6.4 of the German Clean Air Act (Clean Air Act dated 01.10.2002 / VDI 2440 Section 3.3.1.3).

The basics are the "Testing principles for the suitability verification of stem seals in valves as being equivalent in accordance to the German Clean Air Act of the TÜV Süddeutschland Bau und Betrieb GmbH dated 22 September 1992.

The manufacture's declaration contains the suitability verification of an internal flange connection in accordance to VDI 2440 with regard to tightness and the observance of the specific leakage rate according to the German Clean Air Act $\lambda \leq 10^{-4} \frac{\text{mbar} \cdot \text{l}}{\text{s} \cdot \text{m}}$ and an extended test under the above-mentioned operating conditions.

Manufacturer's declaration validity is dependent on the operating instructions being read and observed. In particular, service must be conducted at regular intervals and the bolted connection relevant for tightness should be inspected and retightened if necessary.

Kempen, 01.03.2010

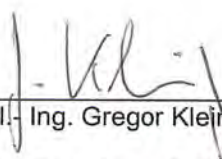

Dipl.-Ing. Gregor Kleinig

Leiter Forschung & Entwicklung
Manager Research & Development

Erstellt/Compiled: CRM/GK am/on : 23.02.2010
Genehmigt/Approved: CRQ/AI am/on: 23.02.2010



Dipl. Wirt.- Ing. Alexander Linges

Leiter Qualitätsmanagement
Quality Manager

QM-Nr.: 0905-40-1022_Rückschlagventil/4-04

Seite/Page : 1
von/of : 1

Safety Information / **Declaration of No Objection** Concerning the Contamination of Richter-Pumps, -Valves and Components

1 SCOPE AND PURPOSE

Each entrepreneur (operator) carries the responsibility for the health and safety of his employees. This extends also to the personnel, who implements repairs with the operator or with the contractor.

Enclosed declaration is for the information of the contractor concerning the possible contamination of the pumps, valves and component sent in for repair. On the basis of this information for the contractor is it possible to meet the necessary preventive action during the execution of the repair.

Note: The same regulations apply to repairs **on-site**.

2 PREPARATION OF DISPATCH

Before the dispatch of the aggregates the operator must fill in the following declaration completely and attach it to the shipping documents. The shipping instructions indicated in the respective manual are to be considered, for example:

- Discharge of operational liquids
- remove filter inserts
- lock all openings hermetically
- proper packing
- Dispatch in suitable transport container
- Declaration of the contamination fixed **outside!!** on the packing

Declaration about the Contamination of Richter Pumps, -Valves and Components

The repair and/or maintenance of pumps, valves and components can only be implemented if a completely filled out declaration is available. If this is not the case, delay of the work will occur. If this declaration is not attached to the devices, which have to be repaired, the transmission can be rejected.

Every aggregate has to have it's own declaration.

This declaration may be filled out and signed only by authorized technical personnel of the operator.

Contractor/dep./institute : _____		Reason for transmitting <input checked="" type="checkbox"/> Please mark the applicable	
Street : _____		Repair: <input type="checkbox"/> subject to fee <input type="checkbox"/> Warranty	
Postcode, city: _____		Exchange: <input type="checkbox"/> subject to fee <input type="checkbox"/> Warranty	
Contact person: _____		<input type="checkbox"/> Exchange/ Replacement already initiated/received	
Phone : _____ Fax : _____		Return: <input type="checkbox"/> Leasing <input type="checkbox"/> Loan <input type="checkbox"/> for credit note	
End user : _____			
A. Details of Richter-product:		Failure description:	
Classification: _____		_____	
Article number: _____		Equipment: _____	
Serial number: _____		Application tool: _____	
_____		Application process: _____	
B. Condition of the Richter-product:		Contamination :	
	no¹⁾	yes	no
Was it in operation ?	<input type="checkbox"/>	<input type="checkbox"/>	<input checked="" type="checkbox"/>
Drained (product/operating supply item) ?	<input checked="" type="checkbox"/>	<input type="checkbox"/>	<input type="checkbox"/>
All openings hermetically locked!	<input checked="" type="checkbox"/>	<input type="checkbox"/>	<input type="checkbox"/>
Cleaned ?	<input checked="" type="checkbox"/>	<input type="checkbox"/>	<input type="checkbox"/>
If yes, with which cleaning agent:	_____		
and with which cleaning method:	_____		
¹⁾ if "no", then forward to D. ←		toxic <input type="checkbox"/> <input type="checkbox"/> caustic <input type="checkbox"/> <input type="checkbox"/> inflammable <input type="checkbox"/> <input type="checkbox"/> explosive ²⁾ <input type="checkbox"/> <input type="checkbox"/> mikrobiological ²⁾ <input type="checkbox"/> <input type="checkbox"/> radioactive ³⁾ <input type="checkbox"/> <input type="checkbox"/> other pollutant <input type="checkbox"/> <input type="checkbox"/>	
²⁾ Aggregates, which are contaminated with microbiological or explosive substances, are only accepted with documented evidence of an approved cleaning.		↓	
³⁾ Aggregates, which are contaminated with radioactive substances, are not accepted in principle.			
C. Details of the discharged materials (must be filled out imperatively)			
1. With which materials did the aggregate come into contact ? Trade name and/or chemical designation of operational funds and discharged materials, material properties, e.g. as per safety data sheet (e.g. toxic, inflammable, caustic)			
X Trade name: _____		Chemical designation: _____	
a) _____		_____	
b) _____		_____	
c) _____		_____	
d) _____		_____	
2. Are the materials specified above harmful to health ?		no	yes
		<input type="checkbox"/>	<input type="checkbox"/>
3. Dangerous decomposition products during thermal load ?		<input type="checkbox"/>	<input type="checkbox"/>
If yes, which ones ?		←	

D. Mandatory declaration: We assure that the data in this explanation are truthful and complete and as a signatory I am able to form an opinion about this. We are aware that we are responsible towards the contractor for damages, which results from incomplete and incorrect data. We commit ourselves to exempt the contractor from claims for damages of thirds resulting from incomplete or incorrect data. We are aware that we are directly responsible towards thirds, irrespective of this declaration, which belongs in particularly to the employees of the contractor consigned with the handling repair of the product.

Name of the authorized person (in block letters): _____

_____ Date

_____ Signature

Company stamp

FAX**Fax No. ()****Pages (incl. cover sheet) ()****To:**

()

Richter Chemie-Technik GmbH
Otto-Schott-Straße 2
D-47906 KempenTelefon +49 (0) 21 52/146-0
Telefax +49 (0) 21 52/146-190richter-info@richter-ct.com
www.richter-ct.comContact person:
()Reference:
()Extension:
- ()E-Mail Address:
()Date:
()**Your order No.:** ()**Our Kom. No.:** ()**Serial No.:** ()

Dear Sirs,

The compliance with laws for the industrial safety obligates all commercial enterprises to protect their employees and/or humans and environment against harmful effects while handling dangerous materials.

The laws are such as: the Health and Safety at Work Act (ArbStättV), the Ordinance on Harzadous Substances (GefStoffV, BIOSTOFFV), the procedures for the prevention of accidents as well as regulations to environmental protection, e.g. the Waste Management Law (AbfG) and the Water Resources Act (WHG)

An inspection/repair of Richter products and parts will only take place, if the attached explanation is filled out correctly and completely by authorized and qualified technical personnel and is available.

In principle, radioactively loaded devices sent in, are not accepted.

Despite careful draining and cleaning of the devices, safety precautions should be necessary however, the essential information must be given.

The enclosed declaration of no objection is part of the inspection/repair order. Even if this certificate is available, we reserve the right to reject the acceptance of this order for other reasons.

Best regards
RICHTER CHEMIE-TECHNIK GMBHEnclosures

()