

Series KSE/F, KSE-C/F

Safety Valves with certification spring-loaded



Keep for future use!

This operating manual must be strictly observed before transport, installation, operation and maintenance

Subject to change without notice.

Reproduction is generally permitted with indication of the source.

© Richter Chemie-Technik GmbH

9530-050-en Revision 10 Edition 10/2011

List of Contents

| | | | |
|---|-----------|---|-----------|
| List of Contents | 2 | 7 Operation | 15 |
| Relevant documents | 3 | 7.1 Initial commissioning | 15 |
| 1 Technical data | 3 | 7.2 Shutdown | 15 |
| 1.1 Name plate CE- and body identification | 4 | 7.3 Recommissioning | 15 |
| 1.2 Component identification | 4 | 7.4 Improper operation and their consequences | 15 |
| 1.3 Tightening torques | 4 | 8 Malfunctions | 16 |
| 1.4 Pressure/temperature diagram | 5 | 9 Maintenance | 16 |
| 2 Safety | 6 | 9.1 Screw connections | 17 |
| 2.1 Intended use | 6 | 9.2 Cleaning | 17 |
| 2.2 For the customer / operator | 6 | 9.3 Modification of the safety valve | 17 |
| 2.3 Improper operation | 6 | 9.4 Adjustment of the test pressure | 17 |
| 3 Safety notes for applications in potentially explosive areas based on the Directive 94/9/ EC (Atex 95) | 7 | 9.5 Important notes on dismantling / installation. | 17 |
| 3.1 Intended use | 7 | 9.6 Replacement of components | 17 |
| 5 Transport, storage and disposal | 9 | 9.6.1 Dismantling of the plug..... | 17 |
| 5.1 Transport securing for KSE/F | 9 | 9.6.2 Dismantling of the seat..... | 18 |
| 5.2 Transport securing for KSE -C | 9 | 9.6.3 Installation of the seat | 18 |
| 5.3 Storage | 10 | 9.6.4 Installation of the plug | 18 |
| 5.4 Return consignments..... | 10 | 9.6.5 Installation of the thrust ring | 18 |
| 5.5 Disposal | 10 | 9.7 Dismantling KSE/F 50/80, 80/100, 100/150 KSE-C/F 80/100, 100/150 | 18 |
| 6 Installation | 11 | 9.7.1 Dismantling of the entire upper section / Removal of the seat and plug..... | 18 |
| 6.1 Sizing of the inlet line..... | 11 | 9.8 Assembly KSE/F 50/80, 80/100, 100/150 KSE-C/F 80/100, 100/150 | 19 |
| 6.2 Sizing of the outlet line | 11 | 9.7 Tests..... | 21 |
| 6.2.1 Admissible back pressure | 11 | 9.7.1 Lift..... | 21 |
| 6.2.2 Drainage of condensate..... | 11 | 9.7.2 Test pressure..... | 21 |
| 6.2.3 Discharge conditions and reaction forces..... | 12 | 10 Drawings | 22 |
| 6.3 Valve connecting dimensions | 12 | 10.1 Legend | 22 |
| 6.4 Flange caps and gaskets..... | 12 | 10.2 Sectional drawing KSE/F | 23 |
| 6.5 Direction of flow and installation | 12 | 10.3 Sectional drawing KSE-C/F | 24 |
| 6.6 Grounding | 12 | 10.4 Views | 25 |
| 6.7 Installation..... | 12 | 10.5 Dimensional drawing KSE/F, KSE-C/F | 26 |
| 6.8 Blocking screw (option) | 13 | | |
| 6.9 Gas-tight design (Option) | 13 | | |
| 6.10 Signal transmitter (Option)..... | 13 | | |
| 6.11 Design for highly permeating media (Option) | 14 | | |
| 6.12 Shortened or no lifting lever (Option) | 14 | | |
| 6.13 Travel stop (Option)..... | 14 | | |

Relevant documents

- ◆ Data sheet
- ◆ Declaration of conformity
- ◆ Manufacturer's Declaration German Clean Air Act (TA-Luft)
- ◆ Manufacturer's Declaration SIL
- ◆ Form for Safety Information Concerning the Contamination QM 0912-16-2001_en

On request :

- ◆ Pressure spring table
- ◆ Bellows operating ranges, TIS 0587-02-0006
- ◆ VDTÜV data sheet "Safety valve 871"
- ◆ VDTÜV data sheet "Safety valve 100"

1 Technical data

Manufacturer:

Richter Chemie-Technik GmbH
 Otto-Schott-Str. 2
 D-47906 Kempen, Germany
 Telephone: +49 (0) 2152 146-0
 Fax: +49 (0) 2152 146-190
 E-Mail: richter-info@idexcorp.com
 Internet: <http://www.richter-ct.com>

Designation:

Bellows safety valve with angle-type valve body acc. to DIN 3320-1.

They are direct-acting and spring-loaded and classified as standard safety valves as regards their opening characteristic.

Series **KSE/F** → design standard

Series **KSE-C/F** → design conical sealing surfaces

Certified for vapours/gases **and** liquids.
 Certification number TÜV-SV...871 D/G/F.

Standard safety valve, design and operation to German AD data sheet A2 (on pressure vessels), ISO 4126, EN 1268

Certified to Clean Air Act (TA Luft)

Strength and tightness (P10, P11) of the pressure-bearing body tested to DIN EN 12266-1.

Gas-tight (P12) in the seat to DIN EN 12266-1, leak rate A

Face to face for DN 25/50, 50/80 and 80/100: DIN EN 558-1 basic series 1, ISO 5752 series 1 (DIN 3202 F1),

Face to face for DN 100/150: DIN 3320-3

Flange connecting dimensions:

DIN EN 1092-2 (ISO 7005-2) PN 16,
 or flanges drilled to ASME B16.5 class 150

Materials :

Shell material: Ductile cast iron EN-JS 1049 / ASTM A395

Lining material: PFA/PTFE

on request conductive design

Set pressure :

| Valve size KSE/F | Set pressure (bar) | Valve size KSE-C/F | Set pressure (bar) |
|---------------------|-----------------------|-----------------------|-----------------------|
| 25/50 | 0,4 –13 | | |
| 50/80 | 0,1 - 13 | | |
| 80/100 | 0,1 - 10 | 80/100 | 0,15 - 1 |
| 100/150 | 0,15 - 10 | 100/150 | 0,15 - 1 |

Temperature range: – 60 °C to + 180 °C

See pressure-temperature diagram in [Section 1.4](#)

Valve size inlet/outlet in mm :

KSE/F 25/50, 50/80, 80/100, 100/150

KSE-C/F 80/100, 100/150

Weight:

KSE/F 25/50 ca. 15 kg

KSE/F 50/80 ca. 25 kg

KSE/F, KSE-C/F 80/100 ca. 40 kg

KSE/F, KSE-C/F 100/150 ca. 85 kg

Installation position :

A direction arrow on the body indicates the direction of flow. See [Section 6.5](#).

Dimensions and individual parts:

See sectional drawing in [Section 9](#) and options in [Section 5.8 to 5.13](#).

Options :

- ◆ Travel stop
- ◆ Blocking screw
- ◆ Gas tight design
- ◆ Signal transmitter
- ◆ Design for heavily permeating media (e.g. chlorine)
- ◆ Shorted lifting lever
- ◆ Without lifting lever

See also [Section 5.8 to 5.13](#).

1.1 Name plate CE- and body identification

The stainless steel identification plate is permanently riveted to the body.

Another stainless steel tag plate riveted to the valve indicates the test pressure.

If the customer mounts his identification, it must be ensured that the valve corresponds to the application.

Example name plate:

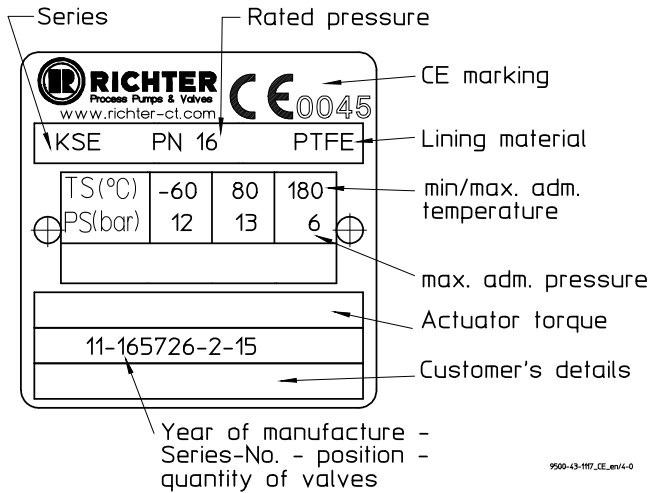

Body identification:

The shell bears the following information in accordance with DIN EN 19 and AD 2000, A4:

- ◆ nominal diameter
- ◆ nominal pressure
- ◆ shell material
- ◆ manufacturer's identification
- ◆ charge number/foundry identification
- ◆ Cast date
- ◆ arrow for direction of flow

1.2 Component identification

Certified safety valves KSE/F and KSE-C/F are identified with a certification plate to the German data sheet A2 (on pressure vessels). This stainless steel plate is riveted to the valve body.

It contains the following details for example:

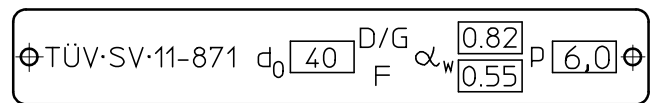

- TÜV = TÜV symbol
- SV = Safety valve
- 11 = Year of certification (here: 2011)
- 871 = Certification number (here: 871)

- d₀ = Narrowest flow Ø in mm (here: 40)
- D/G = intended for discharging vapours/gases
- F = intended for discharging liquids
- α_w = Certified coefficient of discharge (here: 0.82 for D/G and 0.55 for F)
- p = Test pressure in bar (here: 6.0)

1.3 Tightening torques

All screws greased, tighten in diametrically opposite sequence!

The tightening torques for pipe screws and body screws mentioned must not be exceeded. For an exception, see **Section 8** flange connection valve / pipe is leaking.

The following tightening torques are recommended:

Pipe screws, flanges to ISO/DIN

| Flange nom. diameter [mm] | Screws [ISO/DIN] | Torque [Nm] |
|---------------------------|------------------|-------------|
| 25 | 4 x M12 | 10 |
| 50 | 4 x M16 | 26 |
| 80 | 8 x M16 | 25 |
| 100 | 8 x M16 | 35 |
| 150 | 8 x M20 | 65 |

Pipe screws, flanges to ISO/DIN, drilled to ASME Class 150

| Flange nom. diameter [mm] | [inch] | Screws [ASME] | Torque [Nm] | Torque [in-lbs] |
|---------------------------|--------|---------------|-------------|-----------------|
| 25 | 1 | 4 x 1/2" | 8 | 70 |
| 50 | 2 | 4 x 5/8" | 25 | 220 |
| 80 | 3 | 8 x 5/8" | 45 | 400 |
| 100 | 4 | 8 x 5/8" | 35 | 310 |
| 150 | 6 | 8 x 3/4" | 80 | 710 |

Screws body / inlet nozzle

| Valve type | Screws | Torque [Nm] | Torque [in-lbs] |
|------------------------|---------|-------------|-----------------|
| KSE/F 25/50 | 4 x M10 | 12 | 106 |
| KSE/F 50/80 | 4 x M12 | 25 | 221 |
| KSE/F, KSE-C/F 80/100 | 8 x M10 | 20 | 177 |
| KSE/F, KSE-C/F 100/150 | 8 x M16 | 25 | 221 |

Screws body / spring bonnet

| Ventiltyp | Schrauben | Anzugsmoment | |
|-----------------------|-----------|--------------|----------|
| | | [Nm] | [in-lbs] |
| KSE 25/50 | 4 x M12 | 25 | 221 |
| KSE 50/80 | 4 x M12 | 25 | 221 |
| KSE, KSE-C 80/100 | 4 x M12 | 25 | 221 |
| KSE, KSE-C 100/150 | 8 x M12 | 25 | 221 |

Hex. socket screws 914/1 of the bellows gasket

| Valve type | Screws | Torque [Nm] | Torque [in-lbs] |
|---------------------------|--------|-------------|-----------------|
| KSE/F 25/50 | 4 x M8 | 10 | 89 |
| KSE/F 50/80 | 4 x M8 | 12 | 106 |
| KSE/F, KSE-C/F 80/100 | 4 x M8 | 12 | 106 |
| KSE/F, KSE-C/F 100/150 | 8 x M8 | 10 | 89 |

1.4 Pressure/temperature diagram



When used in the minus temperature range, the regulations applicable in the country in question must be observed.

Max. permissible pressure/temperature for the body.

Beim Einsatz unter -10°C (+14°F) bis -60°C (-76°F) muss für den Druckflansch und die Spindel ein Sonderwerkstoff eingesetzt werden.

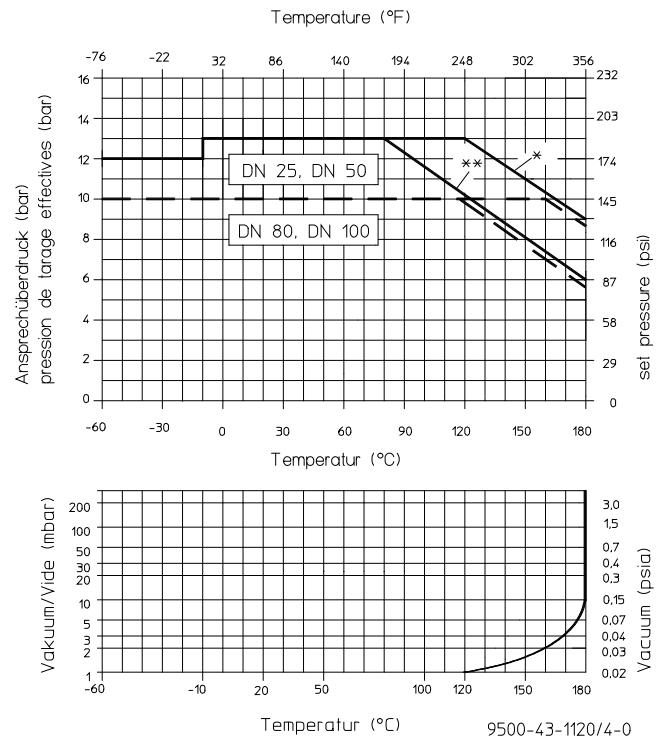

2 Safety

This operating manual contains fundamental information which is to be observed during installation, operation and maintenance.

It must therefore be read before installation and commissioning!

For valves which are used in potentially explosive areas, see **Section 3**.

Installation and operation are to be performed by qualified staff.

The area of responsibility, authority and supervision of the staff must be regulated by the customer.



General hazard symbol !

Peoples may be put at risk.



Safety symbol ! The valve and its function may be put at risk if this safety symbol is not observed..

It is imperative to observe warnings and signs attached directly to the valve and they are to be kept fully legible.

Non-observance of the notes on safety may result in the loss of any and all claims for damages.

For example, non-observance may involve the following hazards:

- ◆ Failure of important functions of the valve/plant.
- ◆ Risk to people from electric, mechanical and chemical effects.
- ◆ Risk to the environment through leaks of hazardous substances.

2.1 Intended use

Richter safety valves of the series KSE/F and KSE-C/F are pressure-maintaining components with safety function in accordance with the Pressure Equipment Directive (DGRL).

They protect the pressure equipment if the admissible pressure limit is exceeded.

KSE/F and KSE-C/F are only intended for vertical installation.

The valves are suitable for vapours, gases and liquids of group 1 in accordance with the DGRL. They have a corrosion-resistant plastic lining.

Safety valves are intended to prevent inadmissible excessive pressures, e.g. in piping systems, pressure vessel plants and boilers. Risks to people, the environment and plants are thus avoided.

Solids can lead to increased wear, leaks, damage to sealing surfaces or to a reduction in the service life of the valve.

The safety valves have been set at the works to the desired test pressure, tested and lead-sealed.

The precise operating conditions of the safety valve selected are documented in the **Data sheet**. It also contains the performance features such as the certified coefficient of discharge, the flow cross area, set pressure, opening pressure, reseating pressure and materials.

If the valve is intended for other operating data, the operator must carefully examine whether the design of the valve, accessories and materials are suitable for the new application.

2.2 For the customer / operator

If a safety valve is used, the operator must ensure that

- ◆ hot or cold valve parts are protected by the customer against being touched
- ◆ the valve has been properly installed in the pipe system
- ◆ the operating conditions stipulated in the data sheet are not exceeded in continuous operating mode.

This is not the manufacturer's responsibility.

Loads caused by earthquakes were not allowed for in the design.

Fire protection to DIN EN ISO 10497 is not possible (plastic lining and plastic components).

2.3 Improper operation

The operational reliability of the valve supplied is only guaranteed if it is used properly in accordance with **Section 2.1** of this operating manual.



The operation limits specified on the name plate must under no circumstances be exceeded.

See also improper operation and their consequences in **Section 7.4**.

3 Safety notes for applications in potentially explosive areas based on the Directive 94/9/ EC (Atex 95)

The valves are intended for use in a potentially explosive area and are therefore subject to the conformity assessment procedure of the directive 94/9/EC (ATEX).

As part of this conformity assessment, an ignition hazard analysis to EN 13463-1 to satisfy the fundamental safety and health requirements was conducted with the following result:

- ◆ **The valves do not have any ignition source of their own.**
- ◆ **The valves are not covered by the scope of application of the ATEX directive and therefore do not need to be identified accordingly.**
- ◆ **The valves may be used in a potentially explosive area.**

It is imperative to observe the individual points of intended use for application in a potentially explosive area.

3.1 Intended use

Improper operation, even for brief periods, may result in serious damage to the valve.

In connection with explosion protection, potential sources of ignition (overheating, electrostatic and induced charges, mechanical and electric sparks) may result from these inadmissible modes of operation; their occurrence can only be prevented by adhering to the intended use.

Furthermore, reference is made in this connection to the Directive 95/C332/06 (ATEX 118a) which contains the minimum regulations for improving the occupational health and safety of the workers who may be at risk from an explosive atmosphere.

A difference is made between two cases for the use of chargeable liquids (conductivity $< 10^{-8}$ S/m):

1. Chargeable liquid and non-conductive lining

Charges can occur on the lining surface. As a result, this can produce discharges inside the valve. However, these discharges cannot cause ignitions if the valve is completely filled with medium.

If the valve is not completely filled with medium, e.g. during evacuation and filling, the formation of an explosive atmosphere must be prevented, e.g. by superimposing a layer of nitrogen.

It is recommended to wait 1 hour before removing the valve from the plant in order to permit the elimination of static peak charges.

This means that, to safely prevent ignitions, the valve must be completely filled with medium at all times or else a potentially explosive atmosphere must be excluded by superimposing a layer of inert gas.

2. Chargeable liquid and conductive lining

No hazardous charges can occur as charges are discharged direct via the lining and shell (surface resistance $< 10^9$ Ohm, leakage resistance $< 10^6$ Ohm).

The following special feature applies to the series with bellows (HV, HVR, BAV, KSE, KSEA, GU, GUT, PA):

The bellows are not offered in a conductive version, i.e. the restrictions under point 1. apply.

Richter optionally offers conductive metallic bellows for the series HV.

Static discharges of non-conductive linings are only produced through the interaction with a non-conductive medium and are therefore the responsibility of the plant operator.

Static discharges are not sources of ignition which stem from the valves themselves!

- The temperature of the medium must not exceed the temperature of the corresponding temperature class or the maximum admissible medium temperature as per the operating manual.
- If the valve is heated (e.g. heating jacket), it must be ensured that the temperature classes prescribed in the Annex are observed.
- To achieve safe and reliable operation, it must be ensured in inspections at regular intervals that the valve is properly serviced and kept in technically perfect order.
- Increased wear to the valve can be expected with the conveyance of liquids containing abrasive constituents. The inspection intervals are to be reduced compared with the usual times.
- Actuators and electric peripherals, such as temperature, pressure and flow sensors etc., must comply with the valid safety requirements and explosion protection provisions.
- The valve must be grounded.
This can be achieved in the simplest way via the pipe screws using tooth lock washers. Otherwise grounding must be ensured by other action, e.g. cable bridges.
- Plastic-lined valves must not be operated with carbon disulphide.

4 Safety note for valves, certified to German Clean Air Act (TA Luft)

On request, this valve can be supplied compliant with the German Clean Air Code.

Certificate / Manufacturer Declaration Validity is dependent on the operating instructions being read and observed.

In particular, servicing must be conducted at regular intervals, and the bolted connections relevant for tightness must be inspected and retightened if necessary.

5 Transport, storage and disposal



It is imperative, for all transport work, to observe generally accepted engineering practice and the accident prevention regulations.



The safety valve is supplied with flange caps. Do not remove them until just before installation. They protect the plastic surfaces against dirt and mechanical damage.

Handle the goods being transported with care. During transport the valve must be protected against impacts and collisions.

Never transport the valve using the lifting lever 238.

See sectional drawing and details in [Section 9](#).

Transport the valve upright in a box or on a pallet on a soft surface and deposit gently on flat ground.

Directly after receipt of the goods, the consignment must be checked for completeness and any in-transit damage.

Do not damage epoxy-coating.

With the KSE/F and KSE-C/F 100/150 valves, a ring bolt **908/1** is screwed into the lifting cap which facilitates transport. It must be ensured that the ring bolt lies on the axis of the discharge flange so that equilibrium is guaranteed when the valve is lifted. See [View W](#) in [Section 10.4](#).

5.1 Transport securing for KSE/F

Safety valves with set pressures ≤ 0.5 bar are fitted at the works with a transport fastening strap which holds the stem in the axial direction and pre-vents damage to the shut-off element as a result of the stem shaking during transport. See [Fig. 1](#).



[Fig. 1](#)

Remove the safety wire between the lifting lever **238** and one connection screw **901/1** of the spring bonnet **513** /body **100** prior to commissioning. See [Section 6.6](#) and [Fig. 2](#).

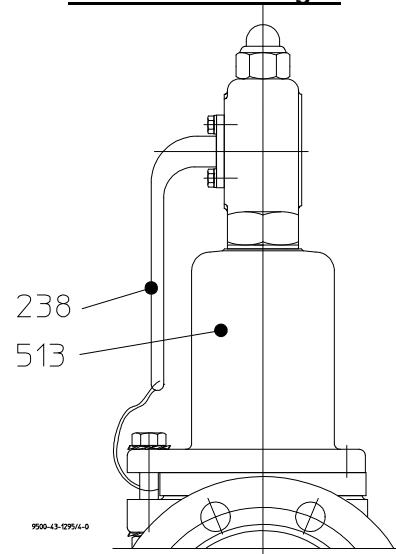

[Fig. 2](#)

5.2 Transport securing for KSE -C

The threaded rod is screwed through the inlet nozzle into the plug. It is inserted through the central bore of the flange cover and screwed against the inlet flange with a wooden disc and a self-locking hex. nut. See [Fig. 3](#).

The flange cover can only be removed when the transport securing screw has been removed. This ensures that it is only possible to install the valve when the stem locking device has been removed.

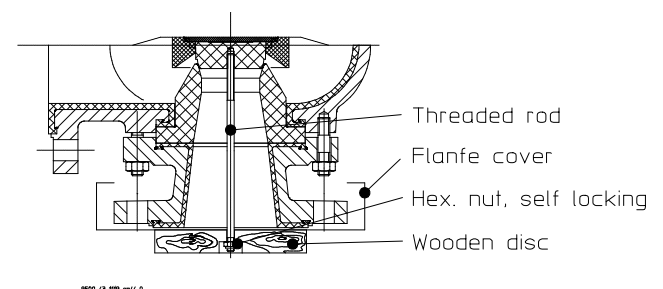

[Fig.3](#)

5.3 Storage

If the valve is not installed immediately after delivery, it must be put into proper storage.

It should be stored in a dry, vibration-free and well ventilated room at as constant a temperature as possible.

Elastomers are to be protected against UV light.

In general, a storage period of 10 years should not be exceeded.

Store the valve in an upright position and secure it from falling over! In case of prolonged storage individual packing with a desiccant may be necessary. Pay attention to local site.

5.4 Return consignments



Valves which have conveyed aggressive or toxic media must be well rinsed and cleaned before being returned to the manufacturer's works.

It is **imperative** to enclose a **safety information sheet / general safety certificate** on the field of application with the return consignment.

Pre-printed forms are enclosed with the installation and operating manual.

Safety precautions and decontamination measures are to be mentioned.

5.5 Disposal

Parts of the valve may be contaminated with medium which is detrimental to health and the environment and therefore cleaning is not sufficient.



Risk of personal injury or damage to the environment due to the medium!

- ◆ Wear protective clothing when work is performed on the valve.
- ◆ Prior to the disposal of the valve:
 - Collect any medium, etc. which has escaped and dispose of it in accordance with the local regulations.
 - Neutralise any medium residues in the valve.
- ◆ Separate valve materials (plastics, metals, etc.) and dispose of them in accordance with the local regulations.

6 Installation

The installation conditions to the AD 2000 Code A2 (on pressure vessels) and TRD721 are to be observed. They are major preconditions for the safe operation of the valve.

- ◆ Examine valve for in-transit damage, damaged globe shut-off or control valves must not be installed.
- ◆ Before installation the valve and the connecting pipe must be carefully cleaned to remove any dirt, especially hard foreign matter.
- ◆ During installation, pay attention to the correct tightening torque, aligned pipes and tension-free assembly.

6.1 Sizing of the inlet line



The admissible pressure loss in the inlet line must not exceed 3% of the set pressure of the safety valve.

The determination of the pressure loss relates to the maximum flow of the valve at 110% of the set pressure and 110% of the certified coefficient of discharge.

- ◆ An excessive pressure loss at the inlet of the safety valve can cause rapid opening and reseating of the valve or chattering.
- ◆ Chattering results in a reduction in the discharge capacity and may cause an inadmissible rise in pressure in the system and damage to the seat sealing surfaces.
- ◆ **The inlet line must never be smaller than the nominal diameter of the safety valve inlet.**
- ◆ Lay supply lines as short as possible.
- ◆ Install, if at all possible, the valve directly on the container to be protected.
- ◆ At least chamfer the container nozzle in the inlet or even better provide with a radius.
- ◆ An inlet nozzle with a tapered design has the best shape in terms of flow.

6.2 Sizing of the outlet line



Outlet lines are to be sized so that reliable functioning of the valve is ensured under all expected operating conditions.

The medium is to be discharged so that there is no risk to people and the environment. The statutory provisions (e.g. accident prevention regulations, and the equivalents of the German Pollution Control Act or the German Clean Air Code) as well as local regulations (works standards) are to be observed.

- ◆ There must be no possibility of the safety valves becoming ineffective due to shut-off elements.

6.2.1 Admissible back pressure

- ◆ **The outlet line must never be smaller than the nominal diameter of the safety valve outlet.**
- ◆ The admissible back pressure in the valve outlet must not be exceeded in order to prevent destruction of the bellows or a reduction in the discharge capacity.

6.2.2 Drainage of condensate

Lay horizontal pipes with a gradient away from the valve so that the liquid medium cannot accumulate in the valve body and that, in the case of gases, no condensate collects in the body.

If outlet lines are laid with a geodetic level difference (e.g. for vapours or gases with a 90° vertical upright pipe bend out of the valve), the bend must not be located directly downstream of the valve.

A horizontal pipe section with a gradient must firstly be installed downstream of the valve.

A draining facility must be provided at the lowest point in the pipe. This opening for the drainage of condensate must be lower than the flow chamber of the body.

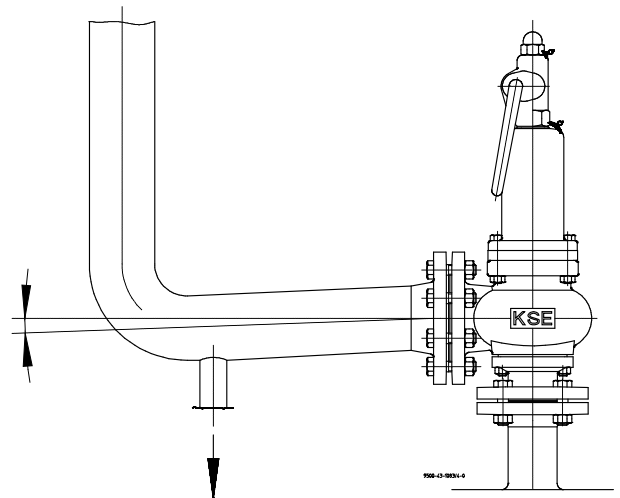

Fig. 4

Lines for the drainage of condensate are to have adequate cross sections. They are to be laid with a gradient and must ensure safe drainage of the medium.

6.2.3 Discharge conditions and reaction forces

At low temperatures:



Outlet lines must be protected against freezing. This applies in particular if gas cooling as a result of expansion is to be expected or lines are laid outdoors.

With crystallising media:



In the case of media which tend to crystallise, solidify or stick, appropriate action must be taken to ensure that the solidification process cannot take place in the inlet or outlet lines or in the body (e.g. installed rupture disc, insulation, heating).

With gassing media:



In the case of gassing or vaporising liquids, adequately dimensioned flashtraps must be located in the direct vicinity of the valve.

Reaction forces during discharge:



The pipes and their holders are to be dimensioned so that their weight forces and the reaction forces and thermal loads produced during discharge can be safely absorbed.

6.3 Valve connecting dimensions

The main dimensions are contained in the sectional drawing in **Section 10.5**.

6.4 Flange caps and gaskets

- ◆ Contamination of or damage to the sealing surfaces is best avoided if the protective caps remain on the flanges until just before installation.

If plastic sealing surfaces can be damaged, e.g. with mating flanges made of metal or enamel, use PTFE-lined seals with a metal inlay.

These are available as special accessories from the Richter product range.

6.5 Direction of flow and installation



When the valve is being installed, the direction of flow must be observed; it is indicated by an arrow on the valve body.

- ◆ A mix-up of the inlet and outlet will result in the valve becoming ineffective and the bellows may be destroyed.
- ◆ Always install the safety valve with the stem in a vertical position.

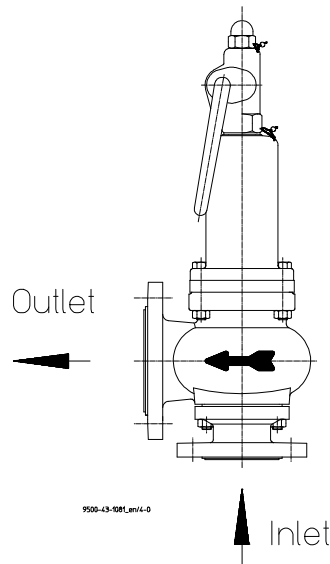

Fig. 5

6.6 Grounding

The valve must be grounded. The simplest solution is to use tooth lock washers which are placed under one pipe bolt of each flange.

At the customer's request a setscrew M6 with a hex. nut and washer will be provided at each flange as an additional grounding connection.

Otherwise grounding must be ensured by different measures e.g. a cable link.

6.7 Installation

- ◆ The plant components to be protected are to be cleaned thoroughly prior to installation of the valve.
- ◆ Solids jeopardise the soft-sealing, high-precision surfaces of the seat and plug and permanent leaks could arise.
- ◆ The safety valve must be installed so that no inadmissible mechanical or thermal stresses are transmitted from the attached pipes to the body.
- ◆ Changes in length of the pipes due to temperature are to be allowed for, e.g. through the installation of expansion joints.
- Remove the flange covers.

For KSE/F: Before installation (vales with set pressures ≤ 0.5 bar), remove metallic transport securing strip and cap nut for securing the valve during transport. Screw on attached lead-sealed cap nut **927/1**. See Section 5.1.

For KSE-C/F: Before commissioning, remove transport securing device. See **Section 5.2**.

- Remove the securing wire between the bonnet **513** and the lifting lever **238**.
- Position and align the safety valve and any additional gaskets. Then tighten the pipe screws with a torque wrench in diametrically opposite sequence. For tightening torques, see **Section 1.3**.

6.8 Blocking screw (option)

During the pressure test of the plant the safety valve cannot discharge through the blocking screw.



◆ This blocking screw may only be used for this purpose. **Always remove again immediately.**

- ◆ Damage to the valve could occur and pressure protection is then no longer provided.
- The lead-sealed cap nut **927/1** is replaced during the pressure test of the plant by a cap nut **927/1B** with an **additional tapped bore** for the blocking screw **901/4**.
- In the KSE/F 100/150 the lead-sealed hex. screw **901/3** is replaced by a threaded rod **918/1** with a prevailing torque type hex. nut **929/2**. The cap nut/blocking screw or the threaded rod/hex. nut are supplied separately. See also the details in **Fig. 5**.
- After the pressure test **remove** the cap nut **927/1B** with the blocking screw **901/4** or threaded rod **918/1** with the hex. nut **929/2** again.
- Screw in the cap nut **927/1** or, in the case of the KSE/F 100/150, the hex. screw **901/4** with the bore for the lead seal again and have them **lead-sealed again**. See also **Fig. 6**.



DN 100/150

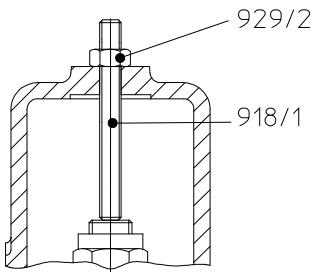

DN 80/100

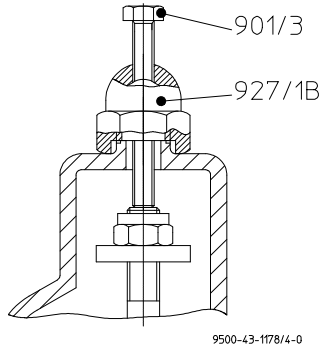

9500-43-1178/4-0

Legend see **Section 10.1**

Fig. 6

6.9 Gas-tight design (Option)

An O-ring **400/4** seals the lifting lever **238**.

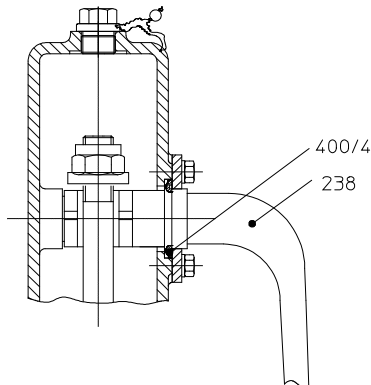

Fig. 7

Legend see **Section 10.1**

6.10 Signal transmitter (Option)

On request, an signal transmitter is available for remote monitoring.

- Glue in stem extension **805** (e.g. Loctite 638) and secure with a hex. nut **920/4**.
- The support, lower part, **542** is screwed on instead of the cap nut **927/1**.
- Insert the O-ring **400/3**.
- Mount support, upper part, **541**.
- Screw in signal transmitter **859**; after adjustment, counter with hex. nut.
- Secure support, upper part, with setscrew **904/1**.
- Design with blocking screw: Insert the O-ring **400/2**, screw in hex. screw **901/4** and lead-seal. See Fig. 10.

DN 25/50, 50/80, 80/100

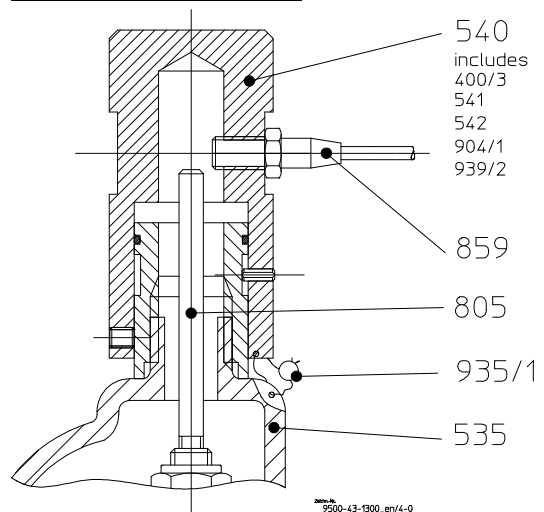
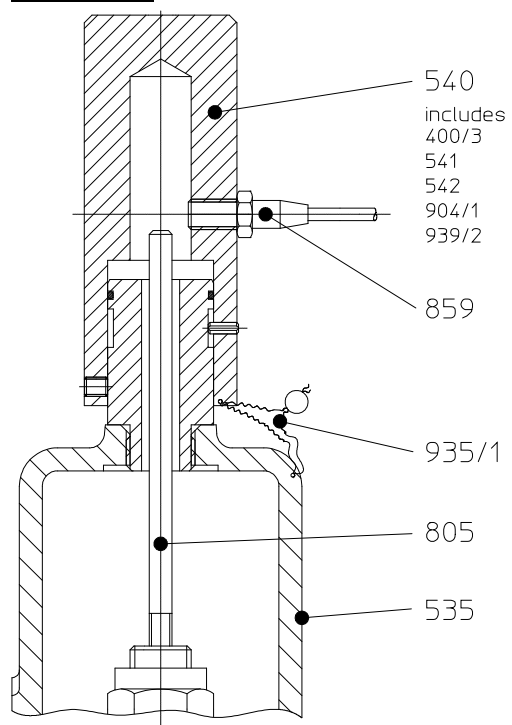

Fig. 8

DN 100/150



9500-43-1301_en/4-0

Fig. 9

Design signal transmitter for blocking screw

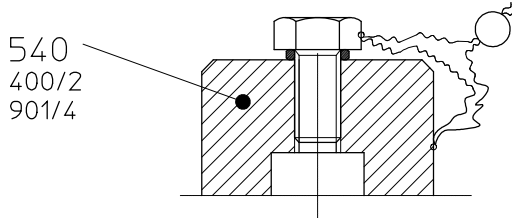

Fig. 10

Legend see **Section 10.1.**

6.11 Design for highly permeating media (Option)

The stem **802**, insert sleeve **308**, parallel pin **561/1**, thrust ring **405**, bearing guide **305** and adjusting screw **538** are made of HC-4.

In addition, with the sizes 80/100 and 100/150 the adjusting screw **538** has a guide bush **307/2** made of PTFE. See **Fig. 11.**

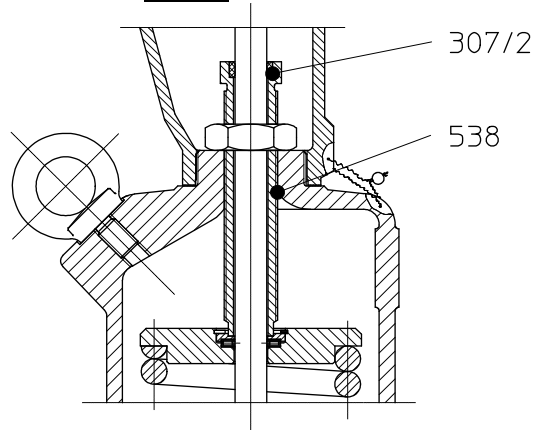

Fig.11

With size 100/150 the bellows guide **860** made of PTFE protects the stem guide **306**. See **Fig. 12.** With the other sizes the stem guide is made of HC-4.

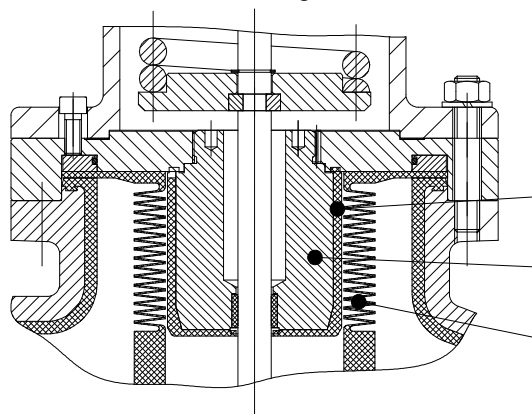

Fig. 12

Legend see **Section 10.1**

6.12 Shortened or no lifting lever (Option)

In order to exclude unauthorised activation, the lifting lever **238** can be shortened; a lever is supplied loose. See **Fig. 13.**

the valve can be without a lifting lever; the locking plate **539** is not bored. See **Fig. 14.**

Fig. 13

Fig. 14

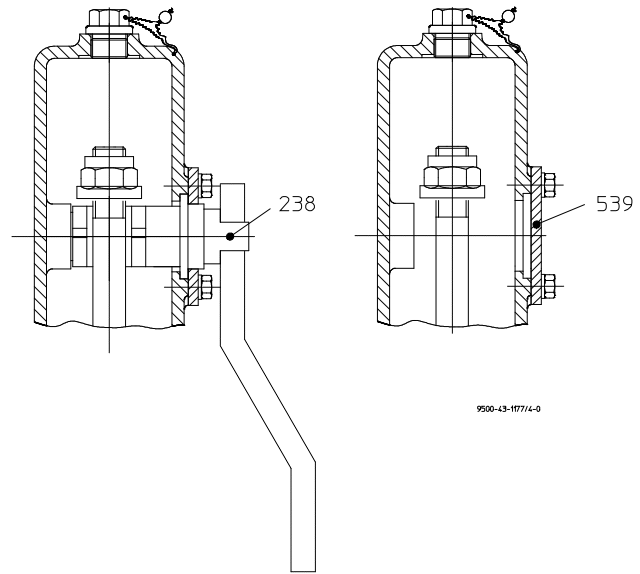

Legend see **Section 10.1**

6.13 Travel stop (Option)

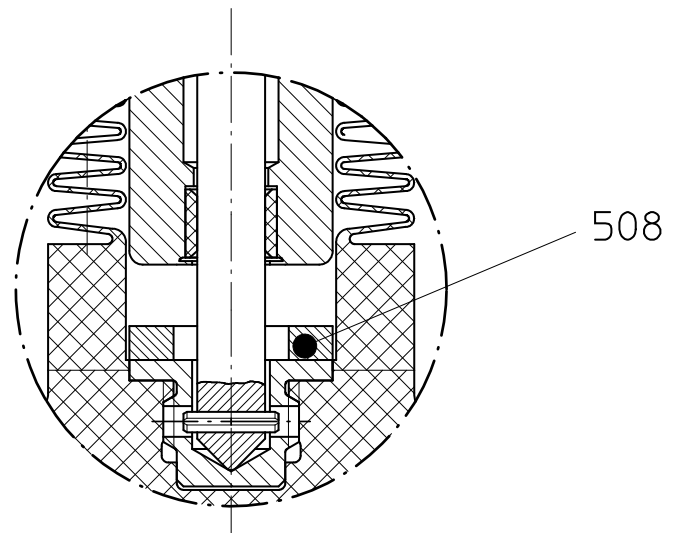

Fig. 15

Legend see **Section 10.1**

7 Operation

7.1 Initial commissioning



Normally, the valves have been tested for leaks with air or water. Normally, the valves have been tested for leaks with air or water.

Unless otherwise agreed, there could be residual amounts of water in the flow section of the valve; this could result in a possible reaction with the medium.

The max. operating pressure of the plant must generally be less than the reseating pressure of the safety valve.

Following the initial loading of the valve with operating pressure and temperature, the torques of all connecting bolts must be checked.

See [Section 1.3](#).

7.2 Shutdown



The local regulations are to be observed when dismantling the valve.

In every case ensure that the pipeline and the vessel have been relieved of pressure and emptied.

- ◆ Appropriate measures are to be taken to prevent human life and the environment being endangered by a leak of aggressive or toxic media.
- ◆ If a dismantled valve is to be returned to the workshop or to the manufacturer, it has to be thoroughly cleaned.
See also [Section 5.4](#).

7.3 Recommissioning

When recommissioning the valve, make sure that **all the appropriate steps** as described in [Section 6.1 to 6.6](#) and [Section 7.1](#) are repeated.

7.4 Improper operation and their consequences

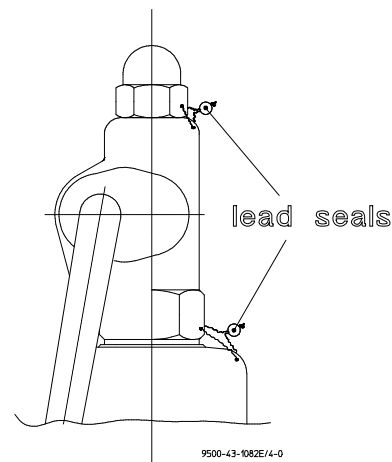



Fig. 16

- ◆ The test pressure, checked by the manufacturer, an approved authority or the supervisory company responsible is secured against unauthorised adjustment by a lead seal.
 - ◆ A broken lead seal must be replaced without delay. This can either be done by the manufacturer, the approved authority or the supervisory company responsible.
-  It is emphasised that in the case of the operating company adding the lead seal itself, it automatically assumes full responsibility for any operational hazard and resulting damage.
- ◆ The travel set at the manufacturer's works ensures reliable operation of the valve. It is forbidden to arbitrarily alter the travel or to totally block the valve.
 - ◆ During operation of the valve, no hard foreign matter may be found between the seat and the plug of the valve.
 - ◆ If foreign matter is deposited on the sealing surfaces during reseating of the valve, the valve is probably not tight. Damage may also occur to the plastic sealing surfaces.

8 Malfunctions

◆ Safety valve is leaking

Is there foreign matter between the seat and plug?

Is there any wear or damage to the seat or plug?

Have the nuts at the inlet nozzle been unevenly tightened?

Actuation of the lifting lever can help to regain the required sealing effect. If this does not succeed in stopping the leak, the sealing surface of the plug must either be reworked or the plug or seat must be replaced.

◆ The lift given in the test certificate is not achieved

Are the bellows impeded in their movement by external influences (e.g. foreign matter, solidified medium between the folds etc.)?

Has the insert sleeve **308** been screwed out of the thread of the bellows?

For measuring the valve lift, see **Section 9.7.1**.

If the required lift is still not attainable after elimination of the disorders, an examination at the manufacturer's is necessary.

◆ Medium is escaping at the bonnet

Have the hex. socket screws **914/1** not been tightened ?

If, after tightening the screws, tightness still cannot be restored, either the plastic lining or the bellows is damaged.

The cause of cracked bellows could have been, for example, an inadmissibly high back pressure during operation of the safety valve. Dismantle the safety valve and have it repaired.

◆ Flange connection leaking

Check the torque of the pipe screws with a torque wrench. If tightness is not achieved, the recommended torque (see **Section 1.3**) may be exceeded by 10%.

If it still proves impossible to stop the leak, then the lining is damaged. Dismantle the valve and check.

◆ The safety valve chatters during discharge

Do the inlet and outlet lines conform to the relevant regulations?

See also **Section 6.1 and 6.2**.

Is the valve oversized ?

Valves which are too large can subsequently be adapted to the mass flow reducing the lift. To this end, the required lift is determined and a travel stop ring is mounted inside the valve.

9 Maintenance



Safety valves must be checked for operability at regular intervals according to the national regulations (in Germany: UVV - pressure vessels, VBG 17 § 32 and TRD 601 sheet 2, paragraph 3.4).

- ◆ The intervals for regular checks are to be laid down by the customer in line with the operating conditions.
- ◆ The lifting lever **238** allows the valves to be actuated from outside, they then open at the operating pressure available. For lifting, the pressure is to be at least 85% of the test pressure.
- ◆ For the arrangement, designation and item numbers of all parts of the valve, see **Section 10**.
- ◆ All repair work is to be performed by qualified personnel using the appropriate tools. Generally recognised practice in mechanical engineering is to be observed.
- ◆ Spare parts are to be ordered with all the details in acc. with the valve identification.
- ◆ Only original spare parts may be installed.

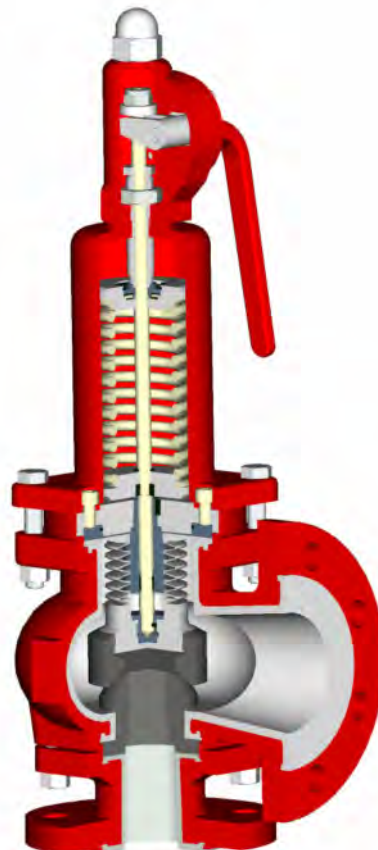

Fig. 17

9.1 Screw connections

To prevent leaks, a regular check of the connection screws should be made in line with the operating requirements.

For tightening torques, see [Section 1.3](#).

To prevent screw connections from becoming loose in the event of pressure fluctuations or plant vibrations, we recommend the installation of expansion joints or pulsation dampers.

9.2 Cleaning



Prior to starting any repair work, the valve is to be thoroughly cleaned. Even if the valve has been properly emptied and rinsed, residual medium may still be found in the valve, e.g. between the lining and body or in the bonnet.

Plastic parts may absorb medium which gradually emerges from the material after cleaning.



Wear the prescribed protective clothing!

Safety valves which have been cleaned with water or other media must be dried before re-assembly of the parts and installation of the valve in the plant.

9.3 Modification of the safety valve

If modifications to the valve are required, the manufacturer must always be consulted.

Examples: Modification with changed test pressure, replacement of the spring or adaption to the mass flow by reducing the travel.

After approval by the manufacturer, these modifications can be performed either by the manufacturer or by the customer under the guidance of a technical supervisory agency or any other approval authority.

9.4 Adjustment of the test pressure

- Undo locking plate **539**, dismantle lifting lever **238** and unscrew the lifting cap **535**.
- Undo nut **920/3**.
- Adjust the spring tension with the adjusting screw **538** to the specified test pressure.
- Counter adjusting screw **538** with a hex. thin nut **920/3** resp. with centering nut **555** (DN 25/50).
- Check test pressure.
- Screw on lifting cap **535** and tighten.
- Insert lifting lever **238**.
- Mount locking plate **539**.

- Have the valve lead-sealed.
- The data specified in the test certificates are to be observed.

9.5 Important notes on dismantling / installation



First relieve plug **204** and lift it off the seat.

- The seat and plug could otherwise be destroyed. Read the precise instructions in [Section 9.6](#).
- Then undo the screws between the body **100** and the inlet nozzle **122** or between the bonnet **513** and body **100**.
 - ◆ Always replace the seat and plug **pairwise** and always rework them **completely**.
 - ◆ Reworking of the seat and plug requires specialised knowledge of the material as well as special lapping wheels.
 - ◆ It is therefore recommended to have this work carried out by the manufacturer.
 - ◆ After dismantling, check all parts for wear and damage.
 - ◆ Observe sectional drawings in [Section 10](#).

9.6 Replacement of components

9.6.1 Dismantling of the plug

- Undo locking plate **539**, dismantle lifting lever **238** and unscrew lifting cap **535**.
- Mark the position of the stem nut **534**.
- Unscrew the prevailing torque type hexagon nut **929/1** and stem nut **534** off the stem **802**.
- When undoing or tightening the prevailing torque type hexagon nut **929/1**, carefully hold the spindle tight with pliers to prevent it from turning.



Do not turn the entire spindle 802! There is a risk that the insert sleeve **308** will be screwed out of the bellows **206** and the folds or the spring-type pin **939/1** will be damaged!

- Mount a suitable distance sleeve (not included in the scope of delivery) over the stem **802**.
- Screw the stem nut **534** against the distance sleeve. The plug **204** is lifted off the seat **205** and the closing force of the valve becomes ineffective.
- Loosen the bolts **901/1**, **936/1**, **936/2** and **920/2** (in the case of KSE/F and KSE-C/F 100/150 **902/2**, **934/1**, **936/1** and **920/2**) and lift the bonnet with internals completely off.
- Grip the bellows **206** in the reinforced section just above the lifting aid **237**. Unscrew the lifting aid off the bellows and remove the plug **204**.

9.6.2 Dismantling of the seat

- Remove bonnet **513** from the body **100**.
See [Section 9.6.1](#).
- Dismantle inlet nozzle **122** from the body **100** and remove the seat **227**.

9.6.3 Installation of the seat

- Insert the new or reworked seat **205** at the bottom into the corresponding centring of the body **100**.
- Then insert the inlet nozzle **122** into the centring of the body **100**.
The components must be smooth running, i.e. can be centred without any constraining forces.
If necessary, the inlet nozzle is to be turned through 90°.
- First tighten the attachment nuts **920/1** hand-tight and then with a torque wrench evenly and in diametrically opposite sequence.



It is imperative to observe the prescribed torques for the connection body / inlet nozzle!
See [Section 1.3](#).

9.6.4 Installation of the plug

- All parts are to be thoroughly cleaned before assembly.
- Centre the new or reworked plug **204** in the lifting aid **237** and screw hand-tight onto the bellows thread. **Counter the bellows 206 at the reinforced section.**
- Undo the hex. socket screws **914/1**. Centre the bonnet **513** with internals on the body **100**. Ensure that there is metallic contact between the body and the bonnet. Then tighten the screws **901/1**, **936/1**, **936/2** and **920/2** (on KSE/F and KSE-C/F100/150 **902/1**, **934/1**, **936/1** and **920/2**).
- Tighten the hex. socket screws **914/1** for the bellows gasket/seal? evenly in line with the tightening torques.
- Undo stem nut **534**.
- Remove distance sleeve.
- Screw stem nut **534** onto the stem **802** up to the marking. Then counter with the prevailing torque type hexagon nut **929/1**.
- When screwing on and countering the prevailing torque type hexagon nut **929/1**, carefully hold the spindle tight with pliers to prevent it from turning.



Do not turn the entire spindle 802!
There is a risk of the folds in the bellows **206** or the spring-type pin **939/1** being damaged!

- Screw on lifting cap **535** and mount lifting lever **238** with locking plate **539**.

9.6.5 Installation of the thrust ring

Make sure that the O-ring **400/1** is positioned completely inside the groove of the pressure ring **124** so that it is not damaged when the thrust ring is inserted into the thrust flange **117**.

If the O-ring **400/1** has been damaged by improper assembly, water may enter from outside into the valve mechanism and the bellows and cause corrosion damage.

A defective O-ring must be replaced before the valve is installed in the plant.

9.7 Dismantling KSE/F 50/80, 80/100, 100/150 KSE-C/F 80/100, 100/150



Caution: During dismantling of the entire KSE/F, the nuts of the fitting between the body and the inlet nozzle must under no circumstances be undone – **Risk of accident!**

The springs must firstly be completely relieved!

9.7.1 Dismantling of the entire upper section / Removal of the seat and plug

- To remove the seat and plug undamaged, the plug **204** must be lifted off the seat **205**.
- Unscrew the cap nut **927/1** from the lifting cap **535** and remove the cap.
- Unscrew the prevailing torque type hexagon nut **929/1** and the stem nut **534** off the spindle **802**.
- When loosening and unscrewing the prevailing torque type hexagon nut **929/1**, carefully hold the spindle tight with pliers to prevent it from turning.



Do not turn the entire spindle 802!
There is a risk of the folds in the bellows **206** or the spring-type pin **939/1** being damaged!

Lifting plug off the seat

- Mount a spacer sleeve (approx. 35 mm long) on the end of the spindle **802** and screw on a nut and counter it with another hex. nut. (Not included in scope of delivery).
- Grease the end surfaces of the spacer sleeve well so that these surfaces cannot "seize" when raising the adjusting screw **538**.
- The spacer sleeve may also be replaced by hex. nuts. See [Fig. 18](#).



Fig. 17

- In order to lift the plug 204 off the seat 205, raise the entire spindle.
- Undo adjusting screw 538 and turn it out of the spring bonnet 513.
- When undoing the adjusting screw 538, hold the spindle with a wrench on the counter nut so that the bellows 206 or the spring-type pin 939/1 are not damaged. See Fig. 18.



Fig. 18

- Unscrew hex. socket screw 914/1 off the pressure ring 124.
- Clean and grease the two threaded rods (approx. 150 mm) long / 180° offset).
- Undo hex. nuts 920/2 to attach the spring bonnet 513 and thrust flange 117.
- Remove complete upper section.
- Press the bellows collar out of the guide of the thrust flanges and then screw the bellows 206 off the spindle 802.
- Assemble the entire upper section (without bellows) again with the body 100.
- Screw hex. nut onto the threaded rod (up to flange contact with spring bonnet 513).
- Screw hex. nuts onto both ends of the threaded rods and counter with more hex. nuts.
- Tighten adjusting screw 538 (turn into the spring bonnet 513) until the spacer sleeve is loose.

- Undo hex. nuts at the end of the spindle and also remove spacer sleeve.
- Undo adjusting screw 538 and screw it out of the spring bonnet 513.
- **The pressure spring 952/1 is only partially relieved in this situation.**
- In order to completely relieve the spring, the two nuts per threaded rod are evenly turned upwards until the spring bonnet is loose.



It is imperative to secure the threaded rods against turning (turning out of the body flange) with a wrench on the counter nut – **Risk of accident!**

See Fig. 19.



Fig. 19

- The KSE/F can now be further dismantled. See relevant Sections in 9.4 to 9.6.

9.8 Assembly

KSE/F 50/80, 80/100, 100/150

KSE-C/F 80/100, 100/150

- Assembly the complete upper section with its internals without the bellows 206, plug 204 and lifting aid 237.
- Grease the outside thread of the adjusting screw and the inside thread in the spring bonnet (for adjusting screw) well and, if difficult to screw, also spray with torsion spray.
- Mount a hex. nut on the free end of the spindle so that when the complete unit is raised the internals are held and they do not fall down. See Fig. 20.



Fig. 20

- Completely mount the lower valve section (body, seat, inlet nozzle). The pressure ring **124** is placed on the sealing strip of the body. See **Fig. 21**.



Fig. 21

- Mount the complete upper section (without bellows **206**, plug **204** and lifting aid **237**) onto the valve body.
- Clean and grease the two threaded rods (approx. 150 mm) lining / 180° offset).
- Tighten spring bonnet **513** with hex. nuts until they sit tightly on the body **100**. See **Fig. 18**.
- The pressure spring **952/1** is now partially pre-tensioned. The view into the outlet flange shows the position of the spindle (distance between the insert sleeve **308** and stem guide **306**).

See **Fig. 22**



Fig. 22

- This must be raised further until the distance between the upper edge of the insert sleeve and the edge of the stem guide is approx. 5 mm.
- In order to raise the spindle **802** into this position, the adjusting screw **538** is now pre-tensioned approx. 25 mm (turned into the bonnet). Then mount a distance sleeve approx. 35 mm long (or hex. nuts with U-washer, see **Fig. 17**) onto the now free spindle end.
- Grease the end surfaces of the spacer sleeve well so that these surfaces cannot "seize".
- A hex. nut is screwed onto the spindle end and countered with another hex. nut. See **Fig. 17**.

- Undo adjusting screw **538** (turn out of the spring bonnet **513**) until the distance between the upper edge of the insert sleeve and the edge of the stem guide is approx. 5 mm. See **Fig. 23**.
- When undoing the adjusting screw **538**, hold the spindle **802** with a wrench on the counter nut to prevent it from turning so that the bellows **206** or the spring-type pin **939/1** are not damaged.



Fig. 23

- Undo the hex. nuts **920/1** (on the flange of the spring bonnet **513**) and lift off the entire upper section.
- Install pressure ring **124** in the thrust flange **117** (observe **Section 9.6.5**) and screw bellows **206** with plug **204** and lifting aid **237** onto the spindle **802**. See **Fig. 24**.



Fig. 24

- Assemble the entire upper section with the body **100**. Tighten the hex. nuts **920/2** and hex. socket screws **914/1** for the pressure ring **124**.

Lowering the bellows onto the seat

- For this purpose screw the adjusting screw **538** into the spring bonnet **513** until the spacer can be freely moved.

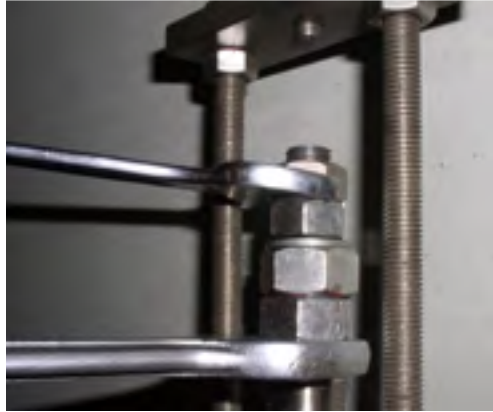

When tightening the adjusting screw **538**, hold the spindle **802** with a wrench on the counter nut to prevent it from turning so that the bellows **206** or the spring-type pin **939/1** are not damaged. See **Fig. 25**.

**Fig.****25**

- Undo the counter nut and remove the spacer.
- Now the valve can be set to the specified set pressure.
- Secure the spindle nut **534** and prevailing torque type hexagon nut **929/1** on the end of the spindle and counter against each other. Set the adjusting screw **538** accordingly.



When screwing the prevailing torque type hexagon nut **929/1** on or off the spindle **802** or when setting the adjusting screw **538**, hold the spindle with a wrench on the counter nut to prevent it from turning so that the bellows **206** or the spring-type pin **939/1** are not damaged. See **Fig. 25**

9.7 Tests

Following the assembly of the valve, the lift and the test pressure must be checked.

9.7.1 Lift**Lift check:**

- Remove the cap nut **935/1** from the lifting cap **535** and determine the height of the stem **802** up to the upper edge of the lifting cap **535**.
- Determine this measurement in both the closed and fully opened state.
- Actuate the lifting lever **238** until the mechanical travel stop can be felt.

The measurement can be made with a slide calliper gauge and a depth indicator to DIN 862.

The lift is derived from the difference in the two heights. It must be at least as high as the lift given in the test certificate.

9.7.2 Test pressure

This test should take place on a test bench with a neutral medium such as air or water. Regarding their suitability and precision, the employed pressure gauges must conform to the requirements of current national regulations (in Germany: e.g. VdTÜV data sheet "Safety Valve 100" of the Association of the German Technical Supervisory Boards).

- ◆ All pressure tests should be carried out in compliance with DIN EN 12266-1 or API 527.
- ◆ It is recommended to use a bubble test with a 5 mm diameter hose positioned 50 mm below the surface of water. The other end of the hose is sealed to the outlet of the valve by means of a plug.
- ◆ To check the test pressure, the pressure in the valve inlet is slowly increased until the valve commences to open.
- ◆ To check the reseating pressure, the pressure in the valve inlet is slowly decreased until the valve is bubble-tight.

10 Drawings

10.1 Legend

| | | |
|--------------|---------------------------------|---|
| 100 | body | Option blocking screw |
| 117 | thrust flange | 901/3 hex. screw |
| 122 | inlet nozzle | 918/1 threaded rod |
| 124 | pressure ring | 927/1B cap nut |
| 204 | plug | 929/2 prevailing torque type hex. nuts |
| 205 | seat | |
| 206 | bellows | Option gas-tight design |
| 237 | lifting aid | 238 lifting lever |
| 238 | lifting lever | 400/4 o-ring |
| 305 | bearing guide | Option signal transmitter |
| 306 | stem guide | 540 support, signal transmitter |
| 307/1 | guide bush | includes: |
| 308 | insert sleeve | 400/2 o-ring (design with blocking screw) |
| 395 | axial-needle roller cage | 400/3 o-ring |
| 396 | axial-washer | 541 support, upper part |
| 400/1 | o-ring | 542 support, lower part |
| 420 | thrust ring, two pieces | 901/4 hex. screw (design with blocking screw) |
| 513 | spring bonnet | 904/1 setscrew |
| 534 | stem nut | 939/2 spring-type pin |
| 535 | lifting cap | 805 stem extension |
| 536 | upper spring plate | 859 signal transmitter |
| 537 | lower spring plate | 920/4 hex. nut |
| 538 | adjusting screw | |
| 539 | locking plate | Option travel stop |
| 554/2 | washer | 508 travel stop |
| 555 | centering nut | |
| 561/1 | grooved pin | Option design for highly permeating media |
| 802 | spindle | 307/2 guide bush |
| 900/1 | ring bolt | 860 spring turn unit |
| 901/x | hex. screw | |
| 902/x | stud screw | |
| 914/1 | hex. Socket screw | |
| 918/1 | threaded rod | |
| 920/x | hex. nut | |
| 920/3 | hex. nut, plain | |
| 927/1 | cap nut | |
| 929/1 | prevailing torque type hex. nut | |
| 932/x | snap ring | |
| 934/1 | lock washer | |
| 935/1 | lead seal | |
| 936/x | toothed lock washer | |
| 938/1 | hex. head screw plug | |
| 939/1 | spring type pin | |
| 952/1 | pressure spring | |

10.2 Sectional drawing KSE/F

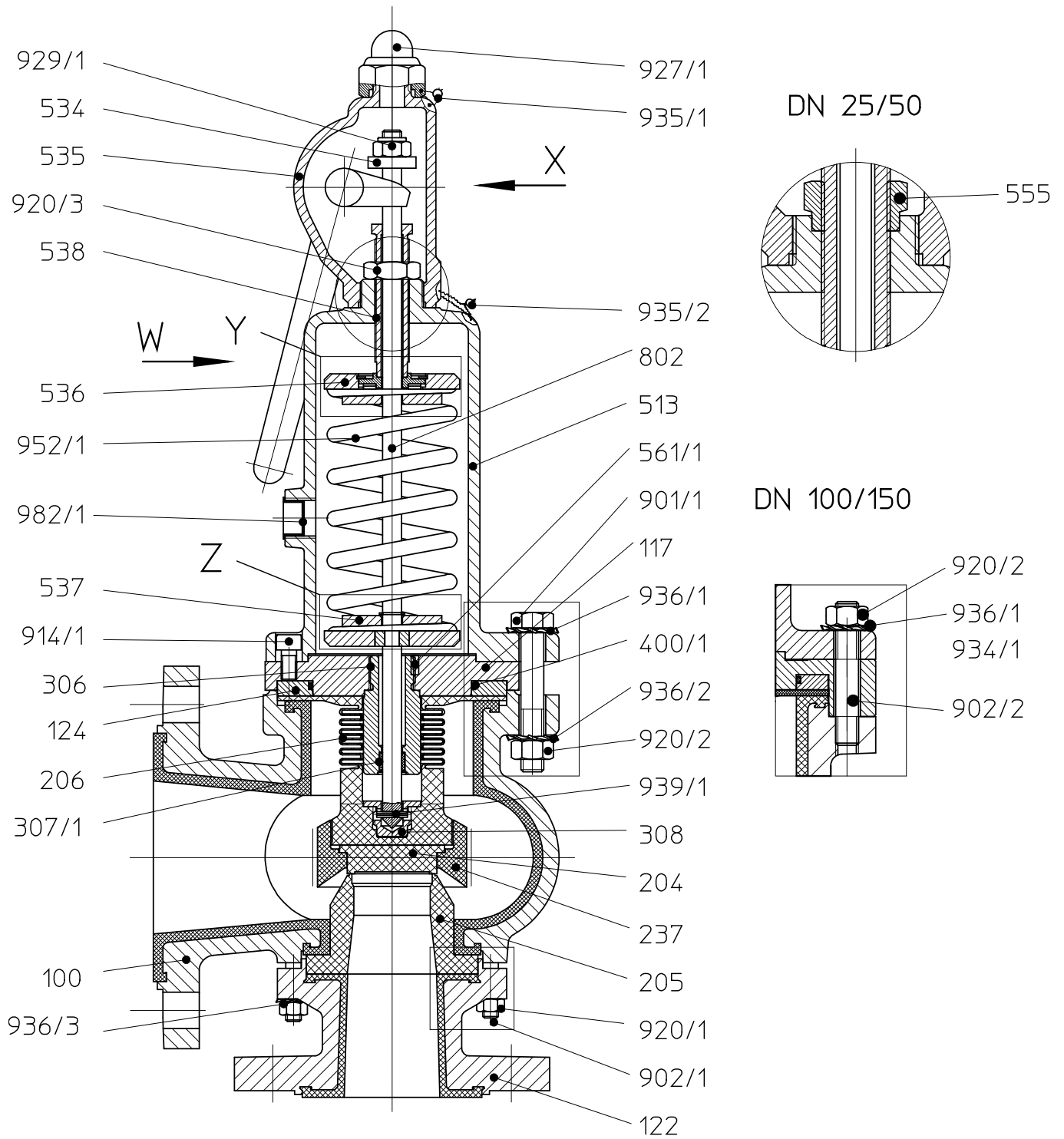

10.3 Sectional drawing KSE-C/F

DN 80/100, 100/150

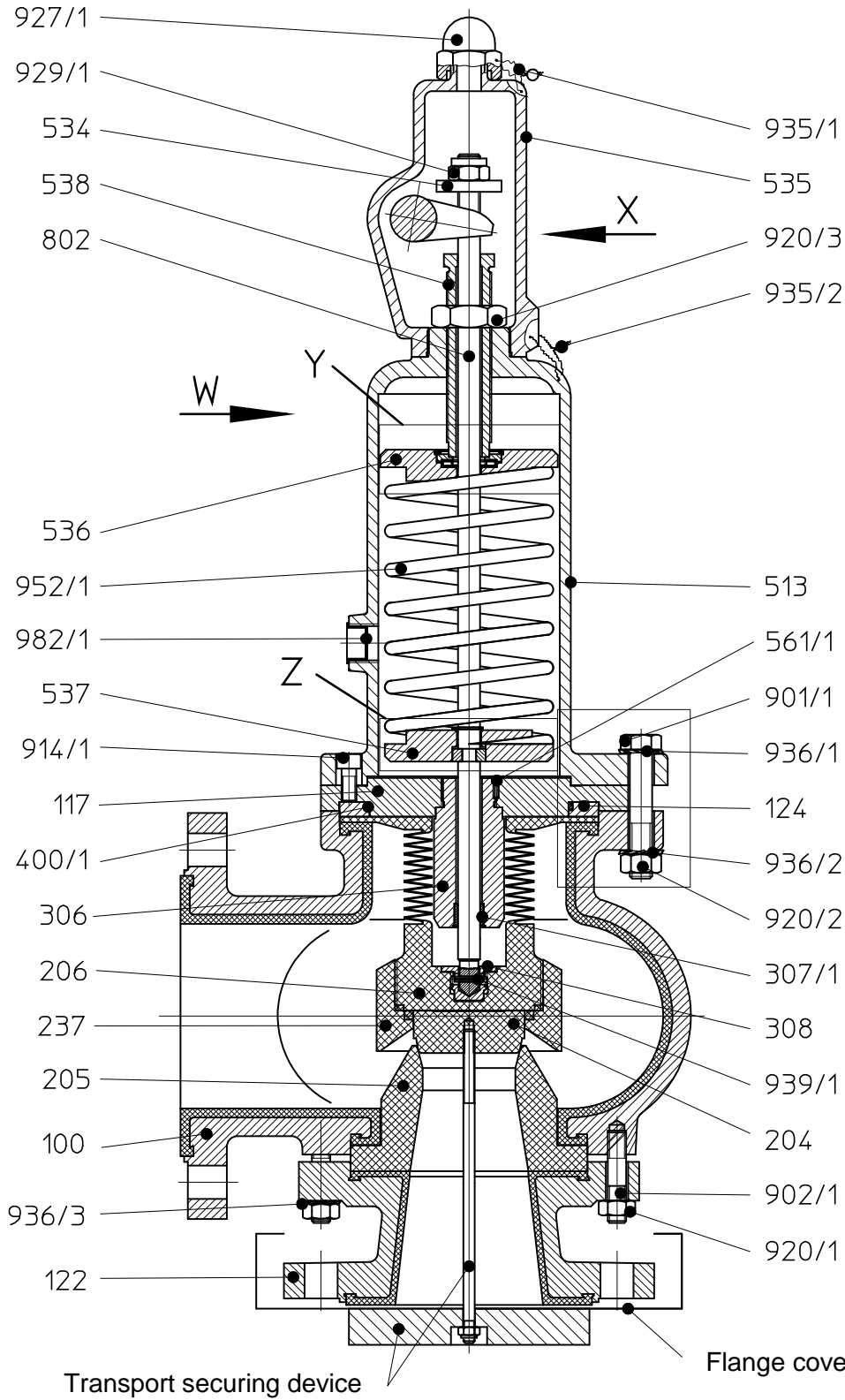

DN 100/150

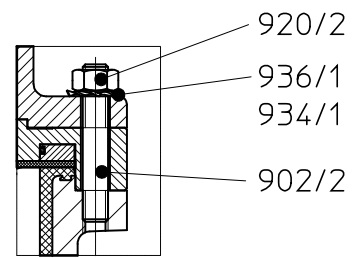

07

10.4 Views

View X

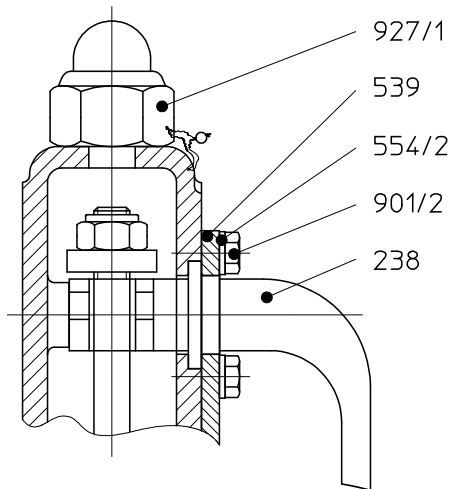

View X

DN 100/150

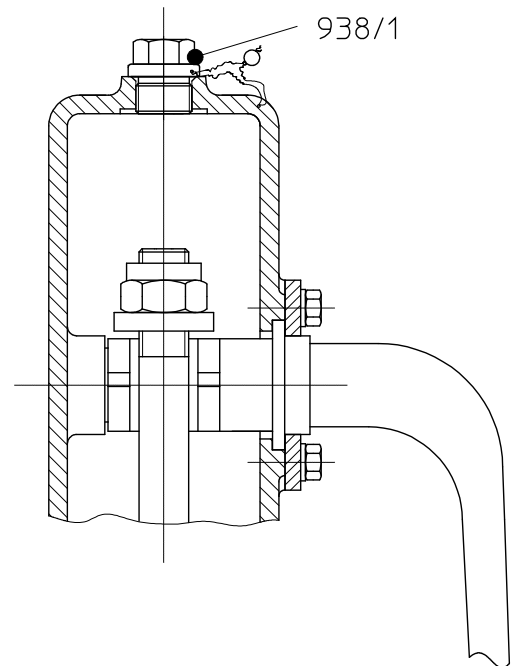

Detail Y

upper spring plate

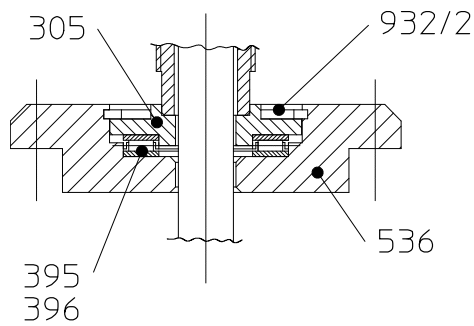

View W

DN 100/150

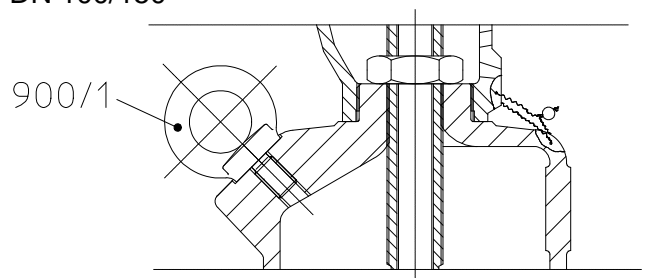

Detail Z

lower spring plate

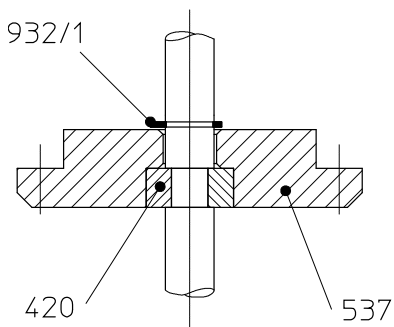

10.5 Dimensional drawing KSE/F, KSE-C/F

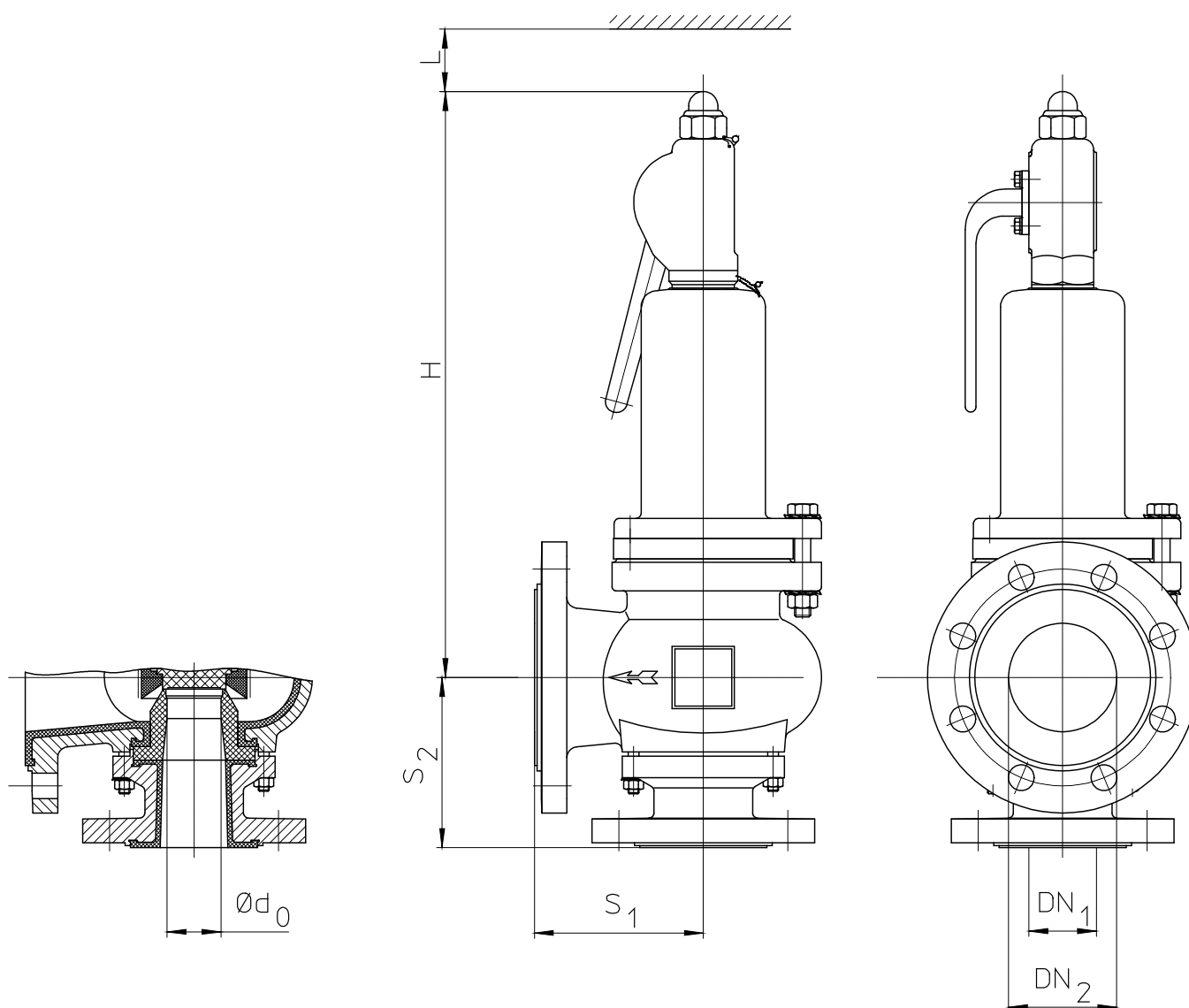

| Nominal diameter | Inlet | | Outlet | | d_0 | H | L |
|------------------|-----------------|----------------|-----------------|----------------|-------|-----|-----|
| | DN ₁ | S ₁ | DN ₂ | S ₂ | | | |
| 25/50 | 25 | 100 | 185 | 100 | 22 | 355 | 120 |
| 50/80 | 50 | 125 | 225 | 125 | 40 | 435 | 120 |
| 80/100 | 80 | 155 | 230 | 155 | 50 | 525 | 140 |
| 100/150 | 190 | 200 | 230 | 220 | 80 | 710 | 180 |

All dimensions in mm

CE Konformitätserklärung nach EN ISO//IEC 17050
Declaration of Conformity according to EN ISO//IEC 17050

| | |
|--|---|
| Produkt <i>Product</i> | Kunststoffausgekleidete Sicherheitsventile <i>Plastic lined safety valves</i> |
| Bauart <i>Design</i> | Sicherheitsventil, Niederdruck-Sicherheitsventil <i>Safety valve, low-pressure safety valve</i> |
| Baureihe <i>Serie</i> | KSE, KSE-C, LPV-A, LPV-D |
| Nennweite <i>Size</i> | DN 25/50, 50/80, 80/100, 100/150, 50, 80, 100 |
| Seriennummer <i>Series number</i> | ab/from 29.12.2009 |
| EU-Richtlinie <i>Directives UE</i> | 97/23/EG Druckgeräterichtlinie <i>97/23/EC Pressure Equipment Directive</i> |
| Angewandte Technische Spezifikation <i>Applied Technical Specification</i> | DIN EN ISO 4126 AD 2000 A2, A4, W-Reihe VdTÜV-Merkblatt Sicherheitsventil 100 DIN EN ISO 12100-2 |
| EG-Baumusterprüfung CE type-examination | TÜV Anlagentechnik GmbH Am Grauen Stein 51105 Köln |
| Überwachungsverfahren <i>Surveillance Procedure</i> | 97/23/EG Zertifizierungsstelle für Druckgeräte der TÜV Nord Systems GmbH & Co. KG Notified Body 0045 |
| Konformitätsbewertungs- verfahren 97/23/EG <i>Conformity assessment procedure 97/23/EC</i> | Modul B + D |
| Kennzeichnung <i>Marking</i> | 97/23/EG CE 0045 |

Das Unternehmen Richter Chemie-Technik GmbH bescheinigt hiermit, dass die o.a. Baureihen die grundsätzlichen Anforderungen der aufgeführten Richtlinien und Normen erfüllt.
Richter Chemie-Technik GmbH confirms that the basic requirements of the above specified directives and standards have been fulfilled.

Kempen, 11.07.2011

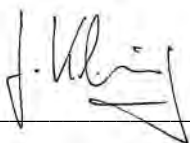

G. Kleining
Leiter Forschung & Entwicklung
Manager Research & Development



A. Linges
Leiter Qualitätsmanagement
Quality Manager

Herstellereklärung / *Manufacturer's Declaration*

TA-Luft / *German Clean Air Act (TA-Luft)*

Richter Sicherheitsventile Richter Safety Relief Valve

Hiermit erklären wir, dass die Niederdruck Überströmventile der Baureihen
Hereby we declare, that the Low-Pressure Safety Valves of the series

KSE, KSEA

die Anforderung bezüglich der Gleichwertigkeit gemäß Ziffer 5.2.6.4 der Technischen Anleitung-Luft (TA-Luft vom 01.10.2002 / VDI 2440 Ziffer 3.3.1.3) erfüllen.

Grundlage sind die "Prüfgrundsätze für den Eignungsnachweis von Spindelabdichtungen in Armaturen als gleichwertig nach TA-Luft" des TÜV Süddeutschland Bau und Betrieb GmbH vom 22.09.1992.

Die Herstellereklärung beinhaltet den Eignungsnachweis einer inneren Flanschverbindung gemäß VDI 2440 hinsichtlich Dichtheit bzw. der Einhaltung der spezifischen Leckagerate nach TA-Luft $\lambda \leq 10^{-4} \frac{\text{mbar} \cdot \text{l}}{\text{s} \cdot \text{m}}$ und einer erweiterten Prüfung unter Betriebsbedingungen.

Voraussetzung für die Gültigkeit der Herstellereklärung ist das Beachten und Einhalten der Betriebsanleitung. Insbesondere sind regelmäßige Wartungsintervalle durchzuführen und die dichtheitsrelevanten Schraubverbindungen zu überprüfen und, wenn notwendig, nachzuziehen.

meets the requirement relating to the equivalence according to Section 5.2.6.4 of the German Clean Air Act (Clean Air Act dated 01.10.2002 / VDI 2440 Section 3.3.1.3).

The basics are the "Testing principles for the suitability verification of stem seals in valves as being equivalent in accordance to the German Clean Air Act of the TÜV Süddeutschland Bau und Betrieb GmbH dated 22 September 1992.

The manufacture's declaration contains the suitability verification of an internal flange connection in accordance to VDI 2440 with regard to tightness and the observance of the specific leakage rate according to the German Clean Air Act $\lambda \leq 10^{-4} \frac{\text{mbar} \cdot \text{l}}{\text{s} \cdot \text{m}}$ and an extended test under the above-mentioned operating conditions.

Manufacturer's declaration validity is dependent on the operating instructions being read and observed. In particular, service must be conducted at regular intervals and the bolted connection relevant for tightness should be inspected and retightened if necessary.

Kempen, 01.03.2010

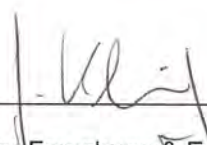

Leiter Forschung & Entwicklung
Manager Research & Development



Leiter Qualitätsmanagement
Quality Manager

Kempen, 27.01.2011

SIL**Declaration by the Manufacturer**

Functional Safety according to IEC 61508

We declare, that the devices

KSE, KSEA

are suitable for use in a safety related application, if the safety instructions and the following parameters are observed:

| | |
|-----------------------------|--|
| Device Type: | A |
| Proof Test Interval: | ≤ 1 year |
| HFT: | 0 (single channel usage) |
| λ_{SU} : | 585 FIT |
| λ_{SD} : | 65 FIT |
| λ_{DU} : | 501 FIT |
| λ_{DD} : | 149 FIT |
| SFF: | 61,4 % |
| PFDAvg: | 2,19 10⁻³ (for T_{Proof} = 1 year) |
| MTBF: | 87,8 years |

Safety Integrity Level: SIL 2

The specified values are valid only for the valve. Accessories such as an actuator, solenoid valves, limit switches etc. are not included.

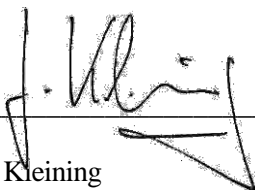

Gregor Kleining
Dir. Research & Development

Alexander Linges
Quality Manager

Safety Information / **Declaration of No Objection** Concerning the Contamination of Richter-Pumps, -Valves and Components

1 SCOPE AND PURPOSE

Each entrepreneur (operator) carries the responsibility for the health and safety of his employees. This extends also to the personnel, who implements repairs with the operator or with the contractor.

Enclosed declaration is for the information of the contractor concerning the possible contamination of the pumps, valves and component sent in for repair. On the basis of this information for the contractor is it possible to meet the necessary preventive action during the execution of the repair.

Note: The same regulations apply to repairs **on-site**.

2 PREPARATION OF DISPATCH

Before the dispatch of the aggregates the operator must fill in the following declaration completely and attach it to the shipping documents. The shipping instructions indicated in the respective manual are to be considered, for example:

- Discharge of operational liquids
- remove filter inserts
- lock all openings hermetically
- proper packing
- Dispatch in suitable transport container
- Declaration of the contamination fixed **outside!!** on the packing

Declaration about the Contamination of Richter Pumps, -Valves and Components

The repair and/or maintenance of pumps, valves and components can only be implemented if a completely filled out declaration is available. If this is not the case, delay of the work will occur. If this declaration is not attached to the devices, which have to be repaired, the transmission can be rejected.

Every aggregate has to have it's own declaration.

This declaration may be filled out and signed only by authorized technical personnel of the operator.

| | | | |
|---|--|--|---|
| Contractor/dep./institute : _____ | | Reason for transmitting <input checked="" type="checkbox"/> Please mark the applicable | |
| Street : _____ | | Repair: <input type="checkbox"/> subject to fee <input type="checkbox"/> Warranty | |
| Postcode, city: _____ | | Exchange: <input type="checkbox"/> subject to fee <input type="checkbox"/> Warranty | |
| Contact person: _____ | | <input type="checkbox"/> Exchange/ Replacement already initiated/received | |
| Phone : _____ Fax : _____ | | Return: <input type="checkbox"/> Leasing <input type="checkbox"/> Loan <input type="checkbox"/> for credit note | |
| End user : _____ | | | |
| A. Details of Richter-product: | | Failure description: | |
| Classification: _____ | | Equipment: _____ | |
| Article number: _____ | | Application tool: _____ | |
| Serial number: _____ | | Application process: _____ | |
| B. Condition of the Richter-product: | | Contamination : | |
| | no ¹⁾ yes no | | no ¹⁾ yes |
| Was it in operation ? | <input type="checkbox"/> <input type="checkbox"/> → | toxic | <input type="checkbox"/> <input type="checkbox"/> |
| Drained (product/operating supply item) ? | ↓ <input type="checkbox"/> <input type="checkbox"/> | caustic | <input type="checkbox"/> <input type="checkbox"/> |
| All openings hermetically locked! | ↓ <input type="checkbox"/> <input type="checkbox"/> | inflammable | <input type="checkbox"/> <input type="checkbox"/> |
| Cleaned ? | <input type="checkbox"/> <input type="checkbox"/> <input type="checkbox"/> | explosive ²⁾ | <input type="checkbox"/> <input type="checkbox"/> |
| If yes, with which cleaning agent: | | mikrobiological ²⁾ | <input type="checkbox"/> <input type="checkbox"/> |
| and with which cleaning method: | | radioactive ³⁾ | <input type="checkbox"/> <input type="checkbox"/> |
| | ← | other pollutant | <input type="checkbox"/> <input type="checkbox"/> |
| ¹⁾ if "no", then forward to D. ²⁾ Aggregates, which are contaminated with microbiological or explosive substances, are only accepted with documented evidence of an approved cleaning. ³⁾ Aggregates, which are contaminated with radioactive substances, are not accepted in principle. | | ↓ | |
| C. Details of the discharged materials (must be filled out imperatively) | | | |
| 1. With which materials did the aggregate come into contact ? Trade name and/or chemical designation of operational funds and discharged materials, material properties, e.g. as per safety data sheet (e.g. toxic, inflammable, caustic) | | | |
| X Trade name: _____ | | Chemical designation: _____ | |
| a) _____ | | _____ | |
| b) _____ | | _____ | |
| c) _____ | | _____ | |
| d) _____ | | _____ | |
| 2. Are the materials specified above harmful to health ? | | no yes | ← |
| | | <input type="checkbox"/> <input type="checkbox"/> | |
| 3. Dangerous decomposition products during thermal load ? | | <input type="checkbox"/> <input type="checkbox"/> | |
| If yes, which ones ? | | | |

D. Mandatory declaration: We assure that the data in this explanation are truthful and complete and as a signatory I am able to form an opinion about this. We are aware that we are responsible towards the contractor for damages, which results from incomplete and incorrect data. We commit ourselves to exempt the contractor from claims for damages of thirds resulting from incomplete or incorrect data. We are aware that we are directly responsible towards thirds, irrespective of this declaration, which belongs in particularly to the employees of the contractor consigned with the handling repair of the product.

Name of the authorized person (in block letters): _____

Date

Signature

Company stamp

FAX**Fax No. ()****Pages (incl. cover sheet) ()****To:**

()

Richter Chemie-Technik GmbH
Otto-Schott-Straße 2
D-47906 KempenTelefon +49 (0) 21 52/146-0
Telefax +49 (0) 21 52/146-190richter-info@richter-ct.com
www.richter-ct.comContact person:
()Reference:
()Extension:
- ()E-Mail Address:
()Date:
()**Your order No.:** ()**Our Kom. No.:** ()**Serial No.:** ()

Dear Sirs,

The compliance with laws for the industrial safety obligates all commercial enterprises to protect their employees and/or humans and environment against harmful effects while handling dangerous materials.

The laws are such as: the Health and Safety at Work Act (ArbStättV), the Ordinance on Harzadous Substances (GefStoffV, BIOSTOFFV), the procedures for the prevention of accidents as well as regulations to environmental protection, e.g. the Waste Management Law (AbfG) and the Water Resources Act (WHG)

An inspection/repair of Richter products and parts will only take place, if the attached explanation is filled out correctly and completely by authorized and qualified technical personnel and is available.

In principle, radioactively loaded devices sent in, are not accepted.

Despite careful draining and cleaning of the devices, safety precautions should be necessary however, the essential information must be given.

The enclosed declaration of no objection is part of the inspection/repair order. Even if this certificate is available, we reserve the right to reject the acceptance of this order for other reasons.

Best regards
RICHTER CHEMIE-TECHNIK GMBHEnclosures

()