

Baureihe/Series/Série

Ausführung **Gleitringdichtungspumpe**

SCK

Design **Mechanical seal pump**

Construction **Pompe à garniture mécanique**



Modification techniques sans préavis, réservées!
Graphique non à l'échelle!
Dimensions variables uniquement revêtues d'une signature!

This leaflet is subject to alteration!
Drawing not to scale!
Certified for construction purposes only when signed!

Technische Änderungen vorbehalten!
Nicht maßstäblich!
Maße nur mit Unterschrift verbindlich!

Maßblatt / dimensional drawing / plan dimensionnel

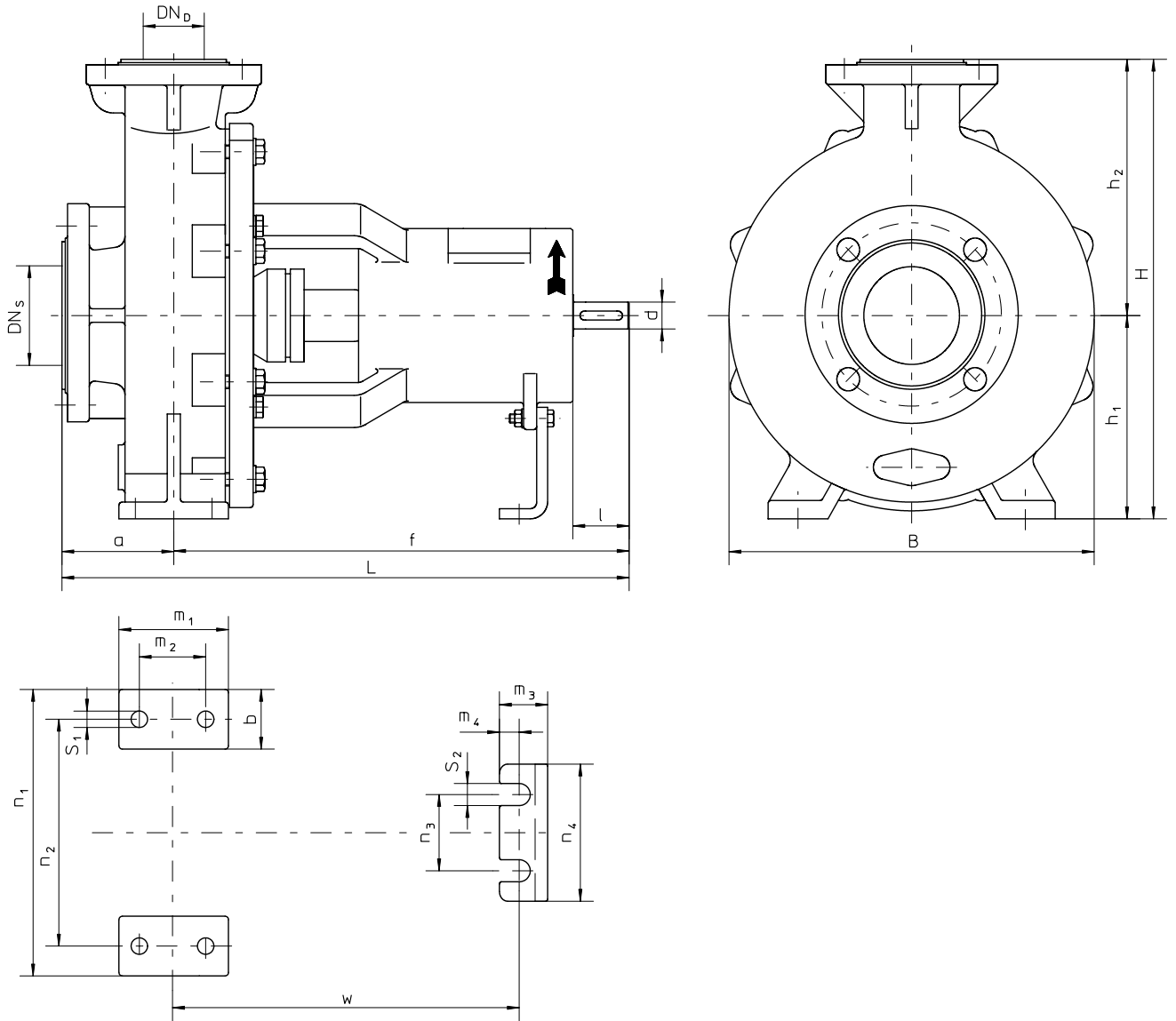

Baureihe/Series/Série Ausführung **Gleitringdichtungspumpe**

SKK

Design **Mechanical seal pump**

Construction **Pompe à garniture mécanique**



Pumpenabmessung
 pump dimensions / encombrements

Pumpengröße Pump size Taille de pompe	DN _s	DN _s	a	B	d	f	H	h ₁	h ₂	L	I
25-25-100	25		55	173	14	316	220	100	120	371	30
25-25-160	25		80	277	24	385	292	132	160	465	50
50-32-160	50	32									
50-32-200	50	32	100	280	24	385	340	160	180	485	50
65-40-200	32	40									
80-50-160	80	50	100	280	24	385	360	160	200	485	50
80-50-200											
80-50-250	80	50	100	280	24	385	405	180	225	625	80
125-80-200											
125-100-200	125	100	125	357	32	500	430	180	250	625	80
125-100-250											
125-100-250	125	100	125	357	32	500	480	200	280	625	80
125-100-250											
150-125-315	150	125	140	415	42	530	505	225	280	670	110
150-125-315	150	125	140	473	42	530	635	280	355	670	110

Maße in mm / dimensions in mm / dimensions en mm

Pumpenfußabmessung
 pump-feet dimensions / dimensions patte-support

Pumpengröße Pump size Taille de pompe	b	m ₁	m ₂	m ₃	m ₄	n ₁	n ₂	n ₃	n ₄	S ₁	S ₂	w	
25-25-100	35	70	50	40	17,5	150	126	110	135	9,5	9,5	240	
25-25-160	50	100	70	46	18	240	190		150	14	14,5	14	285
50-32-160				47									
50-32-200				47									
65-40-200				48	20	265	212						
80-50-160				47	18								
80-50-200				47	18	320	250						
80-50-250	65	125	95	53	23				345	280			
125-80-200	80	160	120			58	24				400	315	
125-100-200	80	160	120	58	24				400	315			
125-100-250	80	160	120			58	24				400	315	
150-125-315	100	200	150	65	27				500	400			22

Maße in mm / dimensions in mm / dimensions en mm

Modification techniques sans préavis, réservées!
 Graphique non à l'échelle!
 Dimensions variables uniquement revêtues d'une signature!
 This leaflet is subject to alteration!
 Drawing not to scale!
 Certified for construction purposes only when signed!
 Technische Änderungen vorbehalten!
 Nicht maßstäblich!
 Maße nur mit Unterschrift verbindlich!