

Baureihe/Series/Série

**NK/F**

Ausführung

**Absperr- und Regelklappen,  
handbetätigt**

Design

**Shut-off and control butterfly valves,  
manually actuated**

Construction

**Vannes papillon d'arrêt et de  
régulation, commande manuelle**



**Maßblatt / dimensional drawing / plan dimensionnel**

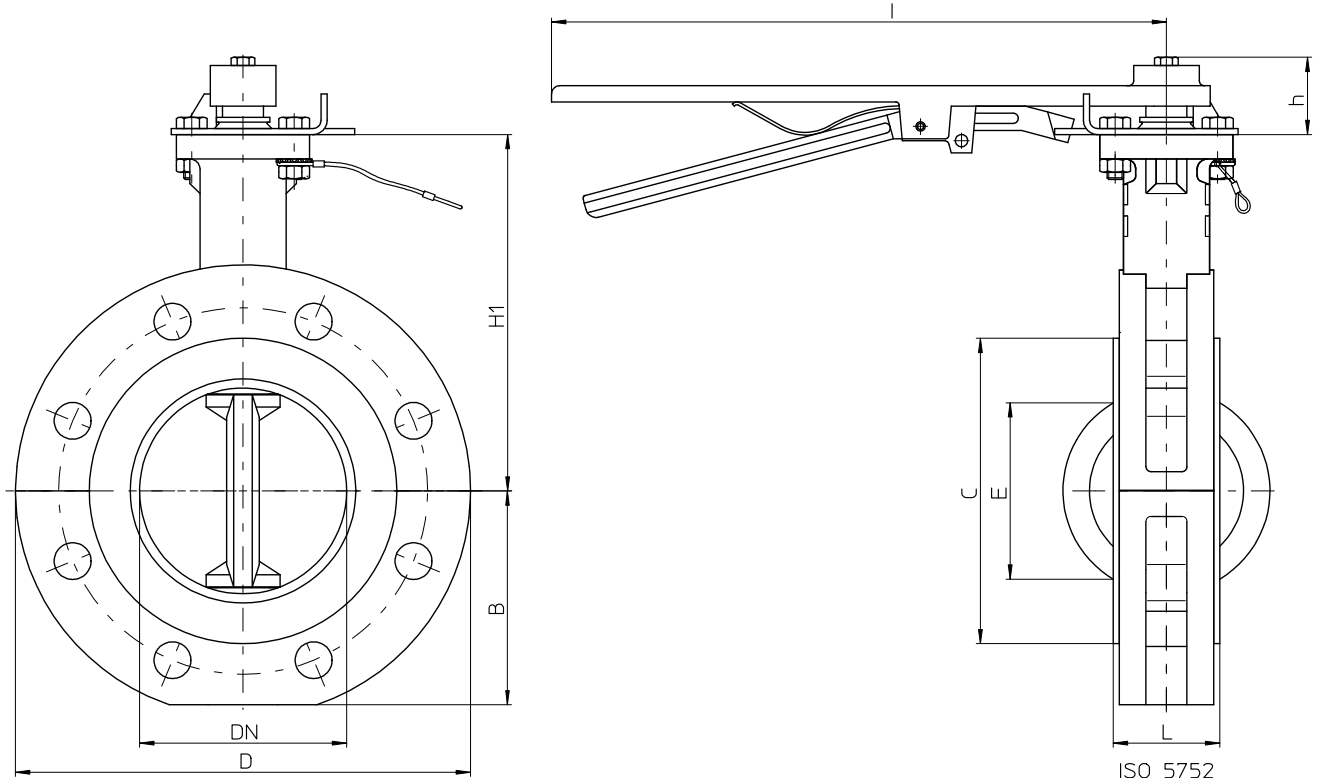

ISO 5752  
Serie 20

Modification techniques possibles sans préavis!  
Graphique non à l'échelle!  
Dimensions variables uniquement revêtues d'une signature!

This leaflet is subject to alteration!  
Draw not to scale!  
Certified for construction purposes only when signed!

Technische Änderungen vorbehalten!  
Nicht maßstäblich!  
Maße nur mit Unterschrift verbindlich!

**DREHARMATUREN / QUARTER TURN VALVE / ÉLÉMENTS DE ROBINETTRIE TOURANTS**

Baureihe/Series/Série

Ausführung

**Absperr- und Regelklappen,  
handbetätigt**

Design

**Shut-off and control butterfly valves,  
manually actuated**

Construction

**Vannes papillon d'arrêt et de  
régulation, commande manuelle**

**NK/F**



DN		50 (2")	80 (3")	100 (4")	150 (6")	200 (8")	250 (10")	300 (12")
H1	mm (inch)	135 (5.31)	160 (6.30)	175 (6.89)	212 (8.35)	232 (9.13)	mit Schneckengetriebe, with wormgear operated, avec engranage à vis sans fin	
h	mm (inch)	40 (1.57)			48 (1.89)			
l	mm (inch)	300 (11.81)			500 (19.68)			
B	mm (inch)	66 (2.60)	93 (3.66)	106 (4.17)	135 (5.31)	165 (6.50)		
L	mm (inch)	43 (1.69)	46 (1.81)	52 (2.05)	56 (2.20)	60 (2.36)		
D	mm (inch)	165 (6.50)	200 (7.87)	222 (8.74)	285 (11.22)	340 (13.39)		
øC	mm (inch)	90 (3.54)	128 (5.04)	150 (5.91)	212 (8.35)	265 (10.43)		
øE	mm (inch)	28 (1.10)	67 (2.64)	87 (3.43)	142 (5.59)	193 (7.60)		

Flanschanschlussmaße:

DIN EN 1092-2, Form B (ISO 7005-2, Form B) PN 16 oder Flansche gebohrt nach ASME B16.5 Class 150

Flange connecting dimensions:

DIN EN 1092-2, type B (ISO 7005-2, type B) PN 16 or flanges drilled to ASME B16.5 Class 150

Dimensions des brides:

DIN EN 1092-2, forme B (ISO 7005-2, forme B) PN 16 ou brides percées selon ASME B16.5 classe 150

Modification techniques possibles sans préavis!  
Graphique non à l'échelle!  
Dimensions variables uniquement revêtues d'une signature!

This leaflet is subject to alteration!  
Draw not to scale!  
Certified for construction purposes only when signed!

Technische Änderungen vorbehalten!  
Nicht maßstäblich!  
Maße nur mit Unterschrift verbindlich!