

Baureihe/Series/Série

Ausführung

**Absperr- und Regelklappen,
fernbetätigt**

Design

**Shut-off and control butterfly valves
remote actuated**

Construction

**Vannes papillon d'arrêt et de
régulation, commande pneumatique**



NKP/F

Modification techniques possibles sans préavis!
 Graphique non à l'échelle!
 Dimensions variables uniquement revêtues d'une signature!

This leaflet is subject to alteration!
 Draw not to scale!
 Certified for construction purposes only when signed!

Technische Änderungen vorbehalten!
 Nicht maßstäblich!
 Maße nur mit Unterschrift verbindlich!

Maßblatt / dimensional drawing / plan dimensionnel

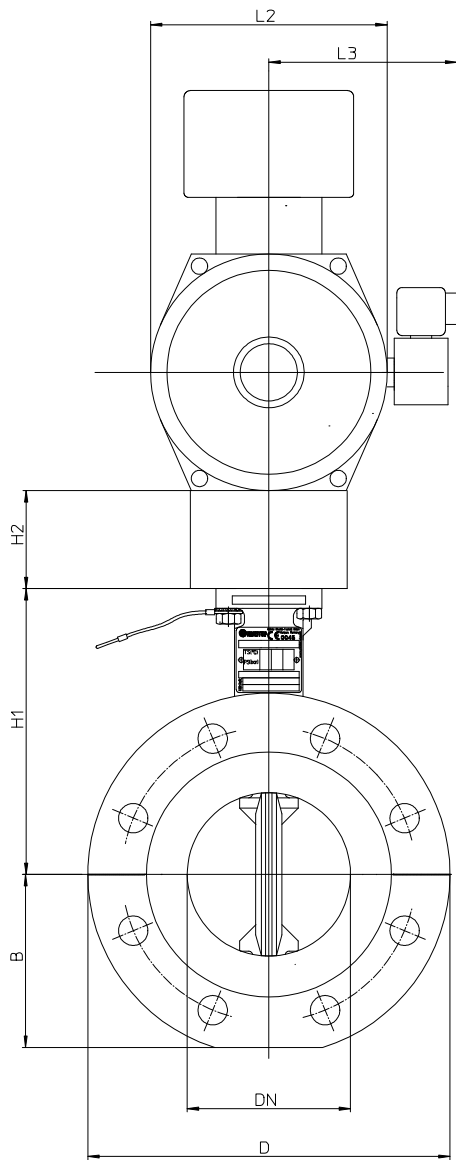

Einzelteil X
Detail X
Detail X

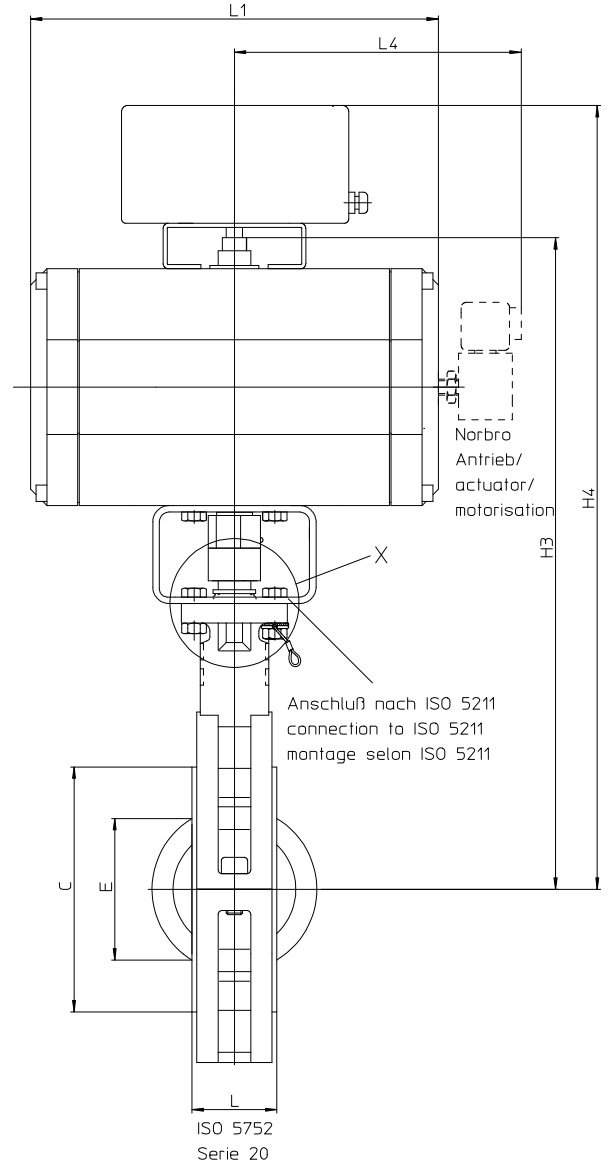
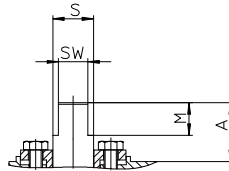

DREHARMATUREN / QUARTER TURN VALVE / ÉLÉMENTS DE ROBINETTRIE TOURANTS

Baureihe/Series/Série

Ausführung

**Absperr- und Regelklappen,
fernbetätigt**

Design

**Shut-off and control butterfly valves
remote actuated**

Construction

**Vannes papillon d'arrêt et de
régulation, commande pneumatique**



NKP/F

Modification techniques possibles sans préavis!
 Graphique non à l'échelle!
 Dimensions variables uniquement revêtues d'une signature!

This leaflet is subject to alteration!
 Draw not to scale!
 Certified for construction purposes only when signed!

Technische Änderungen vorbehalten!
 Nicht maßstäblich!
 Maße nur mit Unterschrift verbindlich!

DN		50 (2")	80 (3")	100 (4")	150 (6")	200 (8")	250 (10")	300 (12")
ISO 5211		F07			F10		F12	
H1	mm (inch)	135 (5.31)	160 (6.30)	175 (6.89)	212 (8.35)	232 (9.13)	272 (10.71)	297 (11.69)
H2	mm (inch)	60 (2.36)			80 (3.15)			
B	mm (inch)	66 (2.60)	93 (3.66)	106 (4.17)	135 (5.31)	165 (6.50)	195 (7.68)	230 (9.06)
L	mm (inch)	43 (1.69)	46 (1.81)	52 (2.05)	56 (2.20)	60 (2.36)	68 (2.68)	78 (3.07)
D	mm (inch)	165 (6.50)	200 (7.87)	222 (8.74)	285 (11.22)	340 (13.39)	405 (15.94)	470 (18.50)
øC	mm (inch)	90 (3.54)	128 (5.04)	150 (5.91)	212 (8.35)	265 (10.43)	315 (12.40)	365 (14.37)
øE	mm (inch)	28 (1.10)	67 (2.64)	87 (3.43)	142 (5.59)	193 (7.60)	243 (9.57)	292 (11.50)
A	mm (inch)	30 (1.18)			36 (1.42)		42 (1.65)	
M	mm (inch)	15 (0.59)		16 (0.63)	20 (0.79)		25 (0.98)	
SW	mm (inch)	10 (0.39)	11 (0.43)	12 (0.47)	18 (0.71)		22 (0.87)	
øS	mm (inch)	14 (0.55)	16 (0.63)	20 (0.79)	25 (0.98)		30 (1.18)	32 (1.26)
H3	mm (inch)							
H4	mm (inch)							
L1	mm (inch)							
L2	mm (inch)							
L3	mm (inch)							
L4 *	mm (inch)							

* Nur Norbro-Antrieb / only Norbro actuator / seulement Norbro motorisation

Flanschanschlussmaße:

DIN EN 1092-2, Form B (ISO 7005-2, Form B) PN 16 oder Flansche gebohrt nach ASME B16.5 Class 150

Flange connecting dimensions:

DIN EN 1092-2, type B (ISO 7005-2, type B) PN 16 or flanges drilled to ASME B16.5 Class 150

Dimensions des brides:

DIN EN 1092-2, forme B (ISO 7005-2, forme B) PN 16 ou brides percées selon ASME B16.5 classe 150